

English Edition

# SERVICE MANUAL

By Portable Document Format

LV-5110U/D78-5152

LV-5110E/D78-5153

**0** PREFACE

**1** General

**2** Repair

**3** Adjustment

**4** Troubleshooting

**5** Parts Catalog

**6** Electrical Diagrams

[Return to Contents](#)

DY8-1785-151 500

**Canon**



**Canon**

**CANON Multimedia Projector**

**LV-5110U**

**D78-5152**

**LV-5110E**

**D78-5153**

**SERVICE  
MANUAL**

## **Technical Documents**

### **Application**

This CD-ROM is issued by Canon Inc. for qualified persons to learn technical theory and product repair. This CD-ROM covers all localities where the products are sold. For this reason, there may be information in this CD-ROM that does not apply to the product sold in your locality.

**The following paragraph does not apply to any countries where such provisions are inconsistent with local law.**

### **Trademarks**

The product names and company names described in this CD-ROM are the registered trademarks of the individual companies.

### **Copyright**

Canon Inc. retains the copyright to all data contained on this CD-ROM. Reproduction, publication (including on the World Wide Web) alteration, translation into another language, or other use of the data in whole or part, contained on this CD-ROM without the written consent of Canon Inc., is prohibited.

### **PDF Files**

This CD-ROM contains PDF files created using Adobe® Acrobat® 4.0J. PDF files can be viewed using Adobe® Acrobat® Reader 4.0 or later.

**Copyright © 2001 by Canon Inc.**

**CANON INC.**

**30-2 Shimomaruko 3-Chome, Ohta-ku,  
Tokyo 146-8501, Japan**

**First published July, 2001**

# PREFACE

## 1. Service Manual Composition

This manual contains information on servicing the product. It has the following sections.

### *Part 1 General Information*

Provides the basic information needed to understand the product.  
(Operating instructions are not included. Refer to the product's instruction book if necessary.)

### *Part 2 Repair Information*

Provides information for disassembly, reassembly, and adjustment of the product, about the tools required, and their application.

### *Part 3 Adjustment*

Provides information for disassembly, reassembly, and adjustment of the product, about the tools required, and their application.

### *Part 4 Troubleshooting*

### *Part 5 Parts Catalog*

### *Part 6 Electrical Diagrams*

## 2. Model Differences

In this series of products, there are models suffixed “J”, “U”, and “E”. The only differences between the models are cosmetic, mainly the designation and rating plates. Internally, they are identical.

Main Marketing Area	Japan	North America	Europe
Model Name	POWER PROJECTOR LV-5110J	MULTIMEDIA PROJECTOR LV-5110U	MULTIMEDIA PROJECTOR LV-5110E

### 3. Tools & Test Equipment

#### 1) General Purpose Tools

Description	Tool No.	Remarks
Ball Driver, 2.0mm hex	CY9-5002-000	Optical Parts Removal & Adjustment
Hex Key Set (w/2.0mm)	CY9-5007-000	Optical Parts Removal & Adjustment
Driver, Ceramic Tip (1.8mm)	CY9-5003-000	Electrical Adjustments
Driver, Slot (4.0mm)	CY9-5004-000	Optical Parts Adjustment
Driver, Cross-point (#2)	CY9-5005-000	Assembly & Disassembly

#### 2) Test Equipment (Local Purchase)

Description	Specifications	Remarks
Digital Multi-meter	1mV – 500V DC	Electrical Adjustment
Video Signal Generator	Color Bars and Gray Scale	Electrical Adjustment
Computer Signal Generator	Gray Scale	Electrical Adjustment
Oscilloscope	100MHz response or over	Waveform checks

#### 3) Other Equipment (Local Purchase)

Description	Specifications	Remarks
Screen	Over 40"	All Adjustment
Personal Computer	Windows 95 OS	All Adjustment

#### 4) Chart/Software (Attached with this manual)

Description	Specifications	Remarks
Monitor Tester	XGA and SVGA	Electrical Adjustment
Gray Scale Chart	Bitmap Data	Electrical Adjustment
Color Shading Correction Tool	Ver. 2.0.2	White Uniformity Adjustment

# CONTENTS

	Page
<i>Part 1: General Information</i>	
<hr/>	
1. FEATURES.....	1-1
1.1 Development objectives.....	1-1
1.2 Major Features.....	1-2
1.3 LV-5110 Features (Details).....	1-3
2. LV-5110 SPECIFICATIONS .....	1-5
2.1 Main unit .....	1-5
2.2 Connectors .....	1-6
2.3 Accessories .....	1-6
2.4 Other specifications .....	1-6
3. NOMENCLATURE .....	1-7
3.1 Main unit .....	1-7
3.2 Top controls .....	1-8
3.3 Rear panel terminals.....	1-9
3.4 Computer Input terminal .....	1-10
3.5 Control port connector .....	1-10
3.6 Remote control .....	1-11
3.7 Operating range.....	1-12
4. COMMENTARY .....	1-13
4.1 External appearance design .....	1-13
4.2 Hybrid gamma correction.....	1-13
4.3 Fan speed control .....	1-14
5. CONNECTING .....	1-15
5.1 Connection to the computer.....	1-15
5.2 Connecting to the video equipment .....	1-16
6. SETTING-UP THE PROJECTOR.....	1-17
6.1 Positioning the projector .....	1-17
6.2 Installation precautions .....	1-17
7. SUPPORTED COMPUTER SYSTEM MODE .....	1-19
<i>Part 2: Repair Information</i>	
<hr/>	
1. SAFETY INSTRUCTIONS .....	2-1
2. CIRCUIT PROTECTIONS .....	2-2
2.1 Fuse.....	2-2
2.2 Thermal Switch .....	2-2
2.3 Warning Temperature and Power Failure Protection .....	2-3
2.4 Air Filter Care and Cleaning .....	2-3
3. MECHANICAL DISASSEMBLIES.....	2-5
3.1 Cabinet Top Removal .....	2-5
3.2 Cabinet Front and Speaker Removal .....	2-5
3.3 Main Board Removal .....	2-6
3.4 Fuse Removal.....	2-6
3.5 AV and Component Board Removal.....	2-7
3.6 Line Filter Board Removal .....	2-7

3.7 Lamp Ballast Unit Fan (FN905) Removal .....	2-8
3.8 Power Board Removal .....	2-8
3.9 Optical Unit and Fan (FN901) Removal.....	2-9
3.10 Audio Amp. Board Removal .....	2-9
3.11 Fans (FN902, FN903, FN904) Removal .....	2-10
3.12 AC Inlet Ass'y Removal .....	2-10
4. OPTICAL PARTS DISASSEMBLIES.....	2-11
4.1 Projection Lens Removal.....	2-11
4.2 Optical Unit Top Removal.....	2-11
4.3 Integrator Lens Ass'y Disassembly.....	2-12
4.4 Relay Lens Ass'y Disassembly .....	2-12
4.5 Polarized Glass-in Ass'y Disassembly.....	2-13
4.6 Polarized Glass-out Ass'y Disassembly.....	2-13
4.7 Locations and Directions .....	2-14
5. LCD PANEL/PRISM ASS'Y REPLACEMENT .....	2-15
5.1 LCD Panel/Prism Ass'y Removal.....	2-15
5.2 Note on LCD Panel/Prism Ass'y Mounting .....	2-16
6. CLEANING.....	2-17
7. LAMP REPLACEMENT .....	2-18

### *Part 3: Adjustment*

---

1. BEFORE ADJUSTMENTS.....	3-1
1.1 Adjustments after Parts Replacement .....	3-2
1.2 Service Adjustment Menu Operation .....	3-3
1.3 Service Conditions .....	3-4
1.4 Service Adjustment Data Table .....	3-5
2. ELECTRICAL ADJUSTMENTS .....	3-7
2.1 Output Voltage Adjustment .....	3-7
2.2 Fan Voltage Adjustment .....	3-7
2.3 PC-Offset Adjustment .....	3-8
2.4 PC Gain Adjustment .....	3-8
2.5 Component Gain Adjustment.....	3-9
2.6 AV Gain Adjustment .....	3-10
2.7 NRS Adjustment .....	3-10
2.8 Signal Center Adjustment .....	3-11
2.9 PC/AV Gamma Off Adjustment .....	3-11
2.10 PC/AV-Video Adjustment-1 .....	3-12
2.11 PC/AV-Video Adjustment-2 .....	3-13
2.12 S/H Clock Adjustment.....	3-13
2.13 Common Center Adjustment .....	3-14
2.14 White Balance Adjustment.....	3-14
2.15 Black Balance Adjustment .....	3-15
2.16 Note on White Uniformity Adjustment.....	3-15
3. OPTICAL ADJUSTMENTS .....	3-16
3.1 Contrast Adujstment .....	3-16
3.2 Integrator Lens Adujstment.....	3-17
3.3 Relay Lens Adjustment.....	3-19
4. TEST POINTS AND LOCATIONS .....	3-20



*Part 4: Troubleshooting*

---

1. TROUBLESHOOTING .....	4-1
1.1 No Power .....	4-1
1.2 No Sound .....	4-6
1.3 No Picture .....	4-7
2. CONTROL PORT FUNCTIONS .....	4-9
2.1 System Control & I/O Port Functions .....	4-9
3. WAVEFORMS .....	4-11
4. IC BLOCK DIAGRAMS .....	4-14

*Part 5: Parts Catalog*

---

*Part 6: Electrical Diagrams*

---

1. PARTS DESCRIPTION AND READING IN SCHEMATIC DIAGRAM .....	6-1
2. PIN DESCRIPTION OF DIODE, TRANSISTOR AND IC .....	6-3
■ Circuit Block Diagram .....	A1
■ Power Supply Lines .....	A2
■ Schematic Diagrams .....	A3
■ Printed Wiring Board Diagrams .....	A10



# *Part 1*

---

## *General Information*



# 1. FEATURES

## 1.1 Development objectives

With its sights firmly fixed on the SOHO-HOME market, Canon introduced the LV-5100 B5 file size microportable\* multimedia projector to consumers last year.

Equipped with a 0.7-inch liquid crystal panel, this LCD projector has been offering a more compact size and greater portability at an even lower cost than before. In contrast, Canon's competitors in this product range have brought out projectors with the same high brightness to be found in liquid crystal projectors featuring 1.3-inch and 0.9-inch liquid crystal panels.

Now following on the heels of the LV-5100 as its successor is the LV-5110 multimedia projector. It employs a high-brightness lamp, and its aim is to maintain the company's competitive edge in this product field while further opening up the market.

\*Microportable: Defined by Canon to mean an LCD projector that weighs less than 3kg.



Fig. 1-1 LV-5110

## 1.2 Major Features

- **Compact, lightweight 2.7kg/B5 file size micro-portable type**  
Real SVGA compatible, class-leading 850 ANSI lumen output
  
- **Supports HDTV&DVD component input**  
Beautiful image reproduction with minimal burring of color
- **Equiped with Digital Keystone function**  
Smoothly corrects for "keystone" effect caused by projector tilt, giving a square image with up to 15 degrees tilt.
  
- **Plug and Play: Simply plug in computer or AV components and start - no adjustments required.**
  - 1) Multiscan System automatically detects PC vertical and horizontal scan frequencies
  - 2) Video color system: Automatically detects system (NTSC/PAL; SECAM/NTSC4.43) PAL-M/PAL-N can be selected from menu bar)
  - 3) Tracking: Auto Imaging function automatically tracks and optimally positions image
  - 4) Graphic User Interface (GUI): The graphic user interface simplifies image adjustments in varying environments.
  - 5) Six Language support: English, French, German, Italian, Spanish and Japanese are supported
  - 6) Wireless Remote Control: Remote control has mouse control functions
  
- **Temperature-sensing Real Time Fan Control: Unobtrusive sound level for conferences**
  
- **Gamma Correction: Gives high quality reproduction of gradation**

## 1.3 LV-5110 Features (Details)

- **Brightest in the SVGA Micro Projector class - 850 ANSI Lumens**
  - 1) Large screen presentation even in brightly lit conference rooms
  - 2) 132W UHP short arc lamp for bright images with great color balance
  
- **Real projection SVG (800 x 600 dot) Digital compression XGA/SXGA high-definition projection \***

0.7" LCD Panels used (for the first time)
  
- **Supports input from HDTV&DVD components**

Color difference signal (Y, Pb/Cb, Pr/Cr) input reproduces the images with minimal burring of color.

\* Composite (Video) input is common to the Brightness (Y) input.
  
- **Digital Keystone distortion compensation**

When the projected image surface and the projector are offset, the image has a trapezoidal shape, but this can be smoothly compensated with offsets up to 15 degrees.

A simple operation gives a square image without adjusting the height of the projector.
  
- **Gamma Correction**

To avoid washed-out whites and murky blacks the user can control the middle brightness.
  
- **Plug and Play: Simply plug in computer or AV equipments and start - no adjustments required.**
  
- **Power Management: improves lamp life**

After a predetermined time (5' 30") with no input signal, the lamp is turned off. When a signal is input, it turns back on.
  
- **Simple wireless remote control**
  - 1) Supports all remote functions
  - 2) P-Timer button supplies presentation elapsed time
  - 3) Functions as the mouse control for connected PC
  
- **Manual zoom and focus controls included**
  
- **Digital zoom enlarges any selected part of the presentation image**
  
- **Cues up the next screen without pausing or projecting an unnecessary operation screen. (Freeze function)**
  
- **The image can be turned off without turning the power off and immediately turned back on - Image shut-off function.**
  
- **Noise is cut in the absence of a signal - Blue Back function.**

- **Impressive image size - up to 200 inches.**
- **Reverse image function allows the unit to be suspended from the ceiling or used as a rear-screen projector.**
- **Reduced lamp problems (Replace Lamp Indication)**
  - 1) The replace lamp indicator shows when it is time for a change.
  - 2) Lamp replacement by the user is simple.
- **The design emphasizes the lens, as you would expect from a Canon product.**

\* With digital compression projection, some information is lost.

XGA: 1024 x 768 dot → 800 x 600 dot when digitally compressed

SXGA: 1280 x 1024 dot → 750 x 600 dot when digitally compressed



## 2. LV-5110 SPECIFICATIONS

### 2.1 Main unit

1. Type:	Micro-portable LCD Projector
2. LCD panel:	0.7" polysilicon active matrix TFT x 3 4:3 aspect ratio
3. Number of pixels:	480,000 pixels (800 H x 600 V) x 3
4. Resolution of display supported:	SXGA & XGA (compression)/SVGA/VGA
5. Light source:	132W UHP lamp
6. Brightness:	850 ANSI lumens
7. Illuminance ratio at edges of image field:	90%
8. Contrast ratio:	300:1
9. Horizontal resolution:	500 TV lines
10. Projection lens:	28 to 33.6mm, 1:2.0 to 2.3, x1.2
11. Lens shifting (U/D ratio):	12:1
12. Elevation adjustment:	UP by 7.5°
13. Size of projection image(in.)/ projection distance(m):	36" (1.4m), 60" (2.4m), 100" (4.0m), 150" (6.0m), 200" (8.0m) in WIDE mode 30" (1.4m), 50" (2.4m), 83" (4.0m), 125" (6.0m), 167" (8.0m) in TELE mode
14. Digital keystone distortion compensation angle:	±15°
15. Noise:	39dB (normal temperature)
16. Color system:	NTSC, PAL, SECAM, NTSC4.43, PAL-M, PAL-N
17. Computer supported:	IBM PC or compatible, Macintosh, PC98, Workstations Note: Some workstations are not supported.

18. Scanning frequency:	15KHz to 80KHz for horizontal sync. 50Hz to 100Hz for vertical sync. Up to 100MHz for dot clock
19. Audio output:	1W monaural
20. Built-in speaker:	40mm x 30mm (1.57" x 1.18"), x 1
21. Rated supply voltage:	100V AC, 50 / 60Hz (Japan) 100 to 120V AC / 200 to 240V AC, 50 / 60Hz (overseas)
22. Power consumption:	210W
23. Operating temperature:	5 to 35°C (41 to 91°F)
24. Storage temperature:	-10 to 60°C (14 to 140°F)
25. Dimensions (W x H x D)	189mm x 75.5mm x 310.8mm (7.44" x 2.97" x 12.24") (Not including adjustment feet) 189mm x 90.5mm x 310.8mm (7.44" x 3.56" x 12.24") (Including adjustable feet)
26. Net Weight:	2.7Kg (5.95 lbs)

## 2.2 Connectors

1. Computer input	
Signal input:	HDB 15-pin x 1
Audio input:	Mini stereo jack x 1
Control port:	Mini DIN 8-pin x 1
2. Audio/Video input	
Video input:	Mini DIN 4-pin x 1 (S-Video) RCA type x 3 (Video/Y, Pb/Cb, Pr/Cr)
Audio input:	Mini stereo jack x 1
3. Audio output:	Mini stereo jack x 1

## 2.3 Accessories

1. Remote Control Transmitter with two AA alkaline batteries
2. VGA Cable
3. Control Cable for PS/2 port
4. Lens Cover
5. Carry Bag
6. AC Power Cord
7. Plug Adapter (Japan model only)
8. Warranty Card
9. Owner's Manual

## 2.4 Other specifications

Service life of lamp:	Approx. 1000 hours
-----------------------	--------------------

### 3. NOMENCLATURE

#### 3.1 Main unit

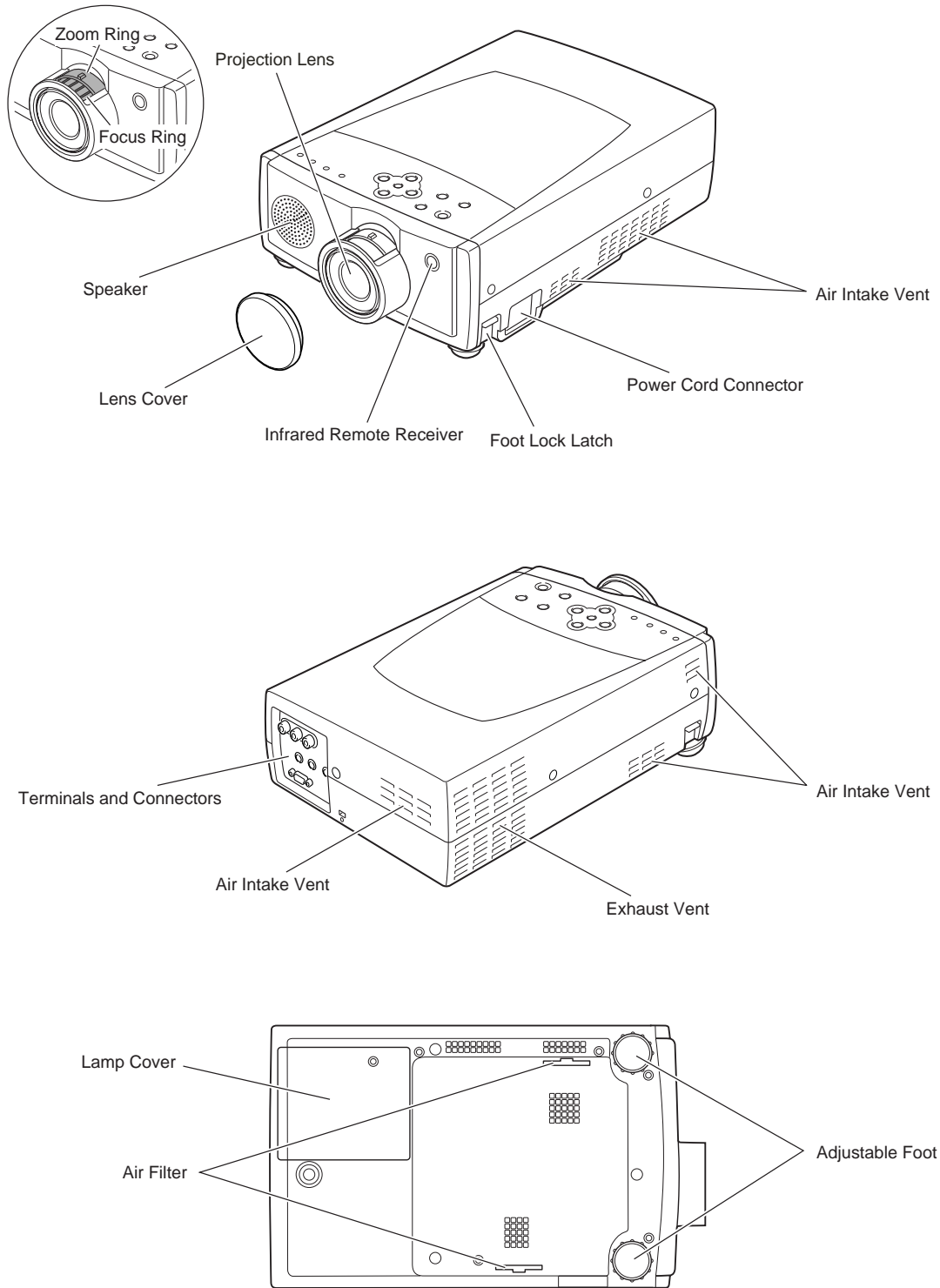

Fig. 1-2

### 3.2 Top controls

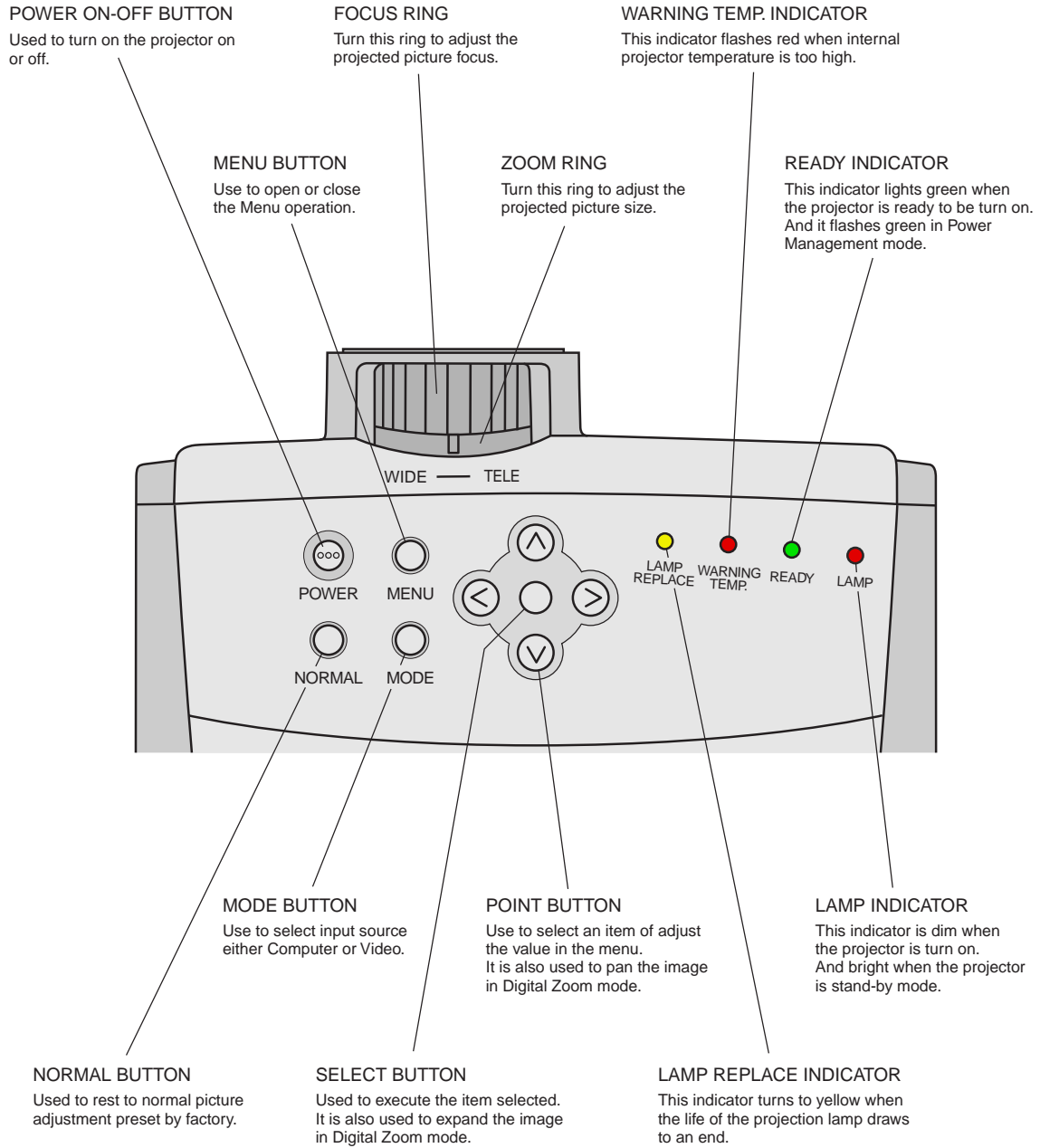

Fig. 1-3

### 3.3 Rear panel terminals

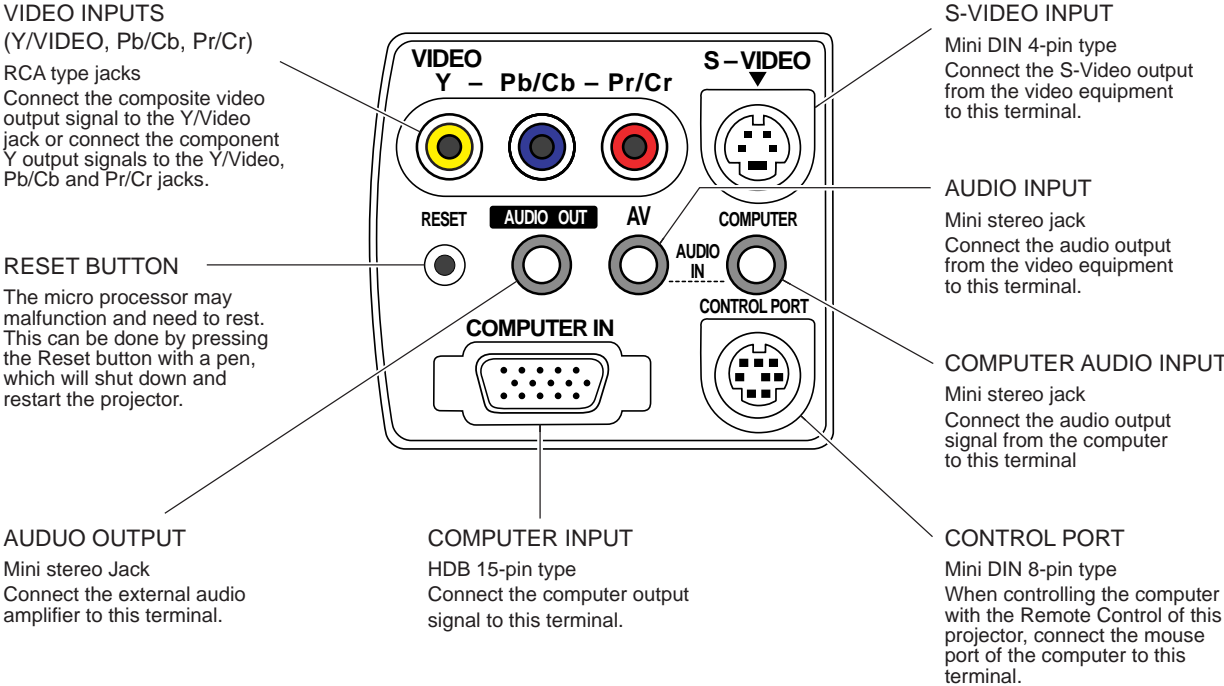
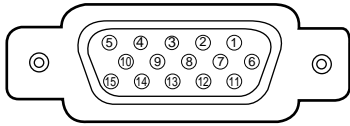

Fig. 1-4

### 3.4 Computer Input terminal

Connect the display output terminal of the computer to this terminal with the VGA Cable (attached).

When connecting the Macintosh computer, the MAC Adapter (optional) is required.



1	Red Input	9	No Connect
2	Green Input	10	Ground (Vert.sync.)
3	Blue Input	11	Sense 0
4	Sense 2	12	Sense 1
5	Ground (Horiz.sync.)	13	Horiz. sync.
6	Ground (Red)	14	Vert. sync.
7	Ground (Green)	15	Reserved
8	Ground (Blue)		

Fig. 1-5

### 3.5 Control port connector

When controlling the computer with the remote control of this projector, connect the mouse port of the personal computer to this terminal.

This terminal does not adapt the PC98 type mouse port.

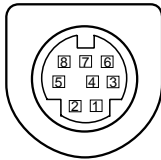

	PS/2	Serial	ADB
1	----	RXD	----
2	CLK	----	ADB
3	DATA	----	----
4	GND	GND	GND
5	----	RTS	----
6	----	TXD	----
7	GND	GND	----
8	----	GND	GND

Fig. 1-6

### 3.6 Remote control

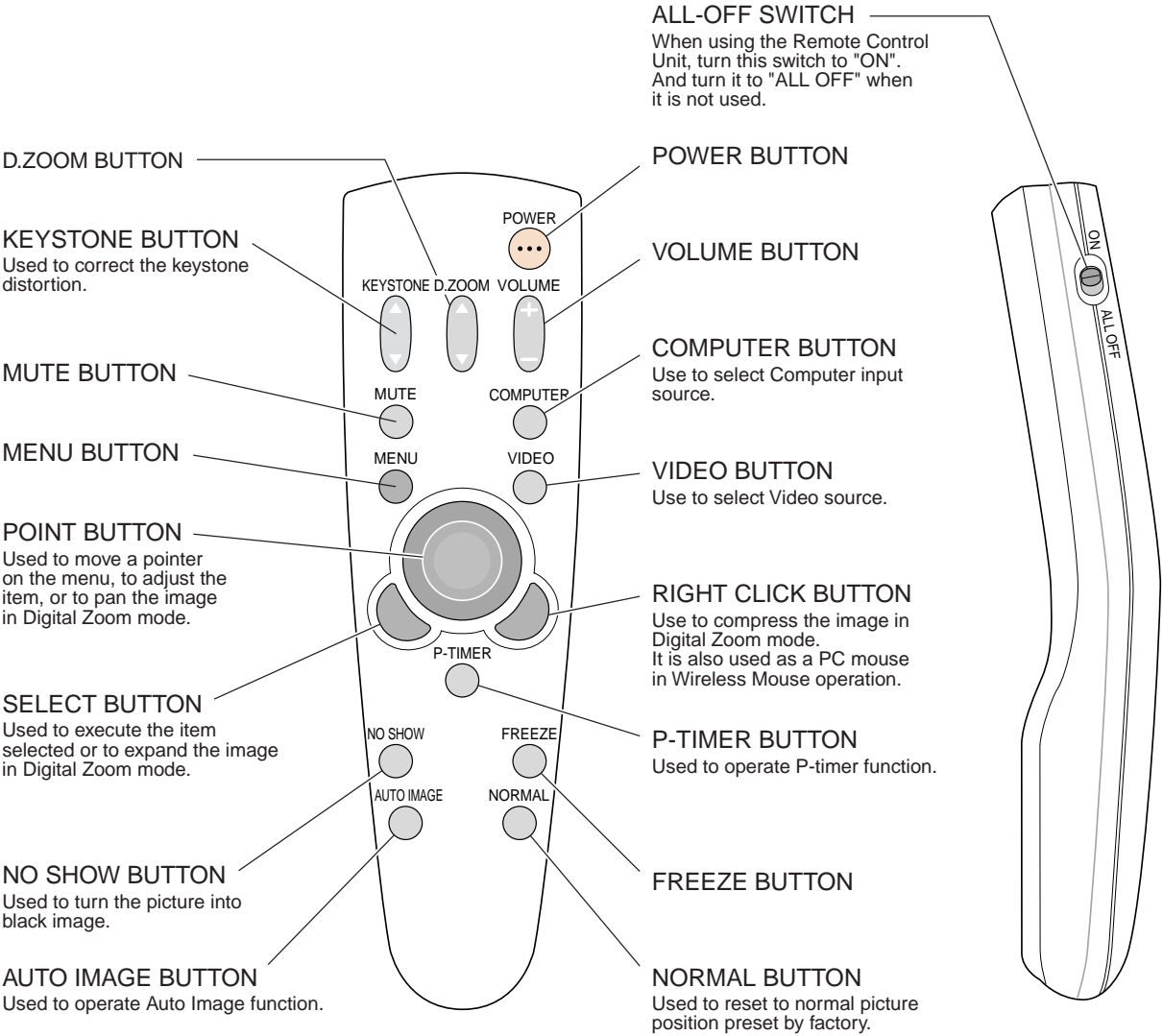

Fig. 1-7

### 3.7 Operating range

Point the remote control toward the projector (receiver's window) when pressing the buttons.

Maximum operating range for the remote control is approximately 5m (16.4') and 60° in front of the projector.

#### Precautions

- Prevent the direct sunlight or strong light from lighting apparatus from striking the infrared remote receiver on the projector.
- Do not look into the laser pointer exit or point it at others.
- Do not dismantle the remote control.

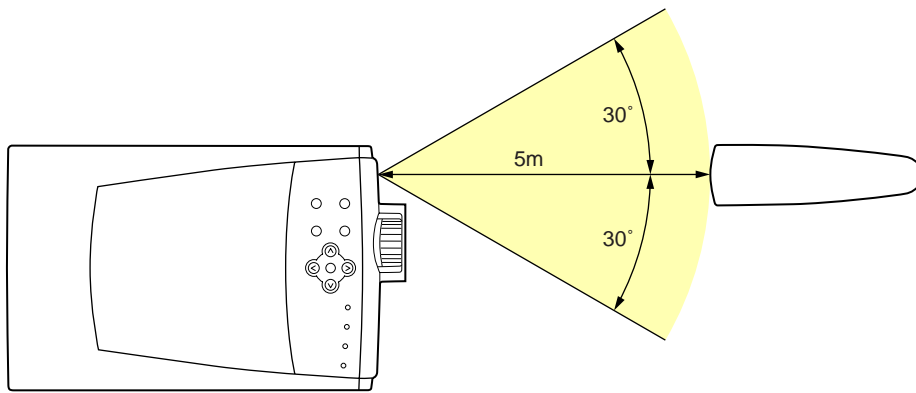

Fig. 1-8



## 4. COMMENTARY

### 4.1 External appearance design

This product follows the same design concept and coloring as the earlier models, LV-7325/LV-7320 to establish a unified image for Canon Multimedia Projectors. Some of the major design points, which are basically the same as the other Canon Multimedia Projectors, are outlined below.

#### ● External Styling

The body is designed with subtle curves and the coloring and semi-transparent body panels follow the lead of the LV-7300 series. Indications of the excellent lens performance are printed around the lens to convey an impression of high picture quality.

#### ● Operating Keys

The operation and cursor key layout is a simple, intuitive layout with grouping to insure ease of use.

#### ● Coloring

The body of the projector is colored glacial blue. The front of the unit, with an appearance fitting a product from an optical equipment manufacturer, has an aluminum lens ring and is colored arctic silver. The overall effect is to emphasize the lens and evoke a sophisticated image.

The operating keys are a special "mercury silver" color that is easy to see in dim light and also serves as a design accent point.

### 4.2 Hybrid gamma correction

Hybrid gamma correction is a new feature. It combines digital gamma correction and analog gamma correction, and takes advantage of the characteristics\* of both. Using the on-screen menu, the user can take advantage of this new feature to control image gradation.

- \* Analog gamma correction: analogue correction is applied to the non-linear analog circuit. In analog correction transitions between gradations are smooth.
- \* Digital gamma correction: Correction is applied through digital processing of the X/Y gamma curve. Using a digital signal, varying the characteristics curve, for example, is simple. Because digital processing is involved, however, transitions between gradations can be abrupt.

### 4.3 Fan speed control

A new feature of this projector is Real Time Fan Control. Temperature sensors control the fan to reduce the fan noise level to an unobtrusive level (39dB) during normal operation.

There are two temperature sensors, sensor 1 measuring ambient room temperature and sensor 2 measuring the temperature in the area of the LCD panels. The outputs of the sensors are sent to the CPU, which then controls the voltage applied to the fan as outlined below.

1. If the internal temperature rises, the fan voltage is changed as shown in the figure below.  
But, if the internal temperature falls, the fan voltage remains unchanged for five minutes, then is changed  
The fan voltage is determined by the higher of the two sensor temperatures.
2. If the temperature sensed by sensor 1 exceeds 51°C, or the temperature sensed by sensor 2 exceeds 57°C, the lamp is extinguished. In this case, the main power switch must be turned off and then back on to resume operation.
3. The fan will continue to run for a maximum of 90 seconds after the power switch is turned off.
4. If the CPU receives no response from a sensor, it determines that the sensor is missing or broken and immediately shuts down the projector.
5. In Service Mode (when operating at high altitude) the fan operates at maximum voltage regardless of room temperature.

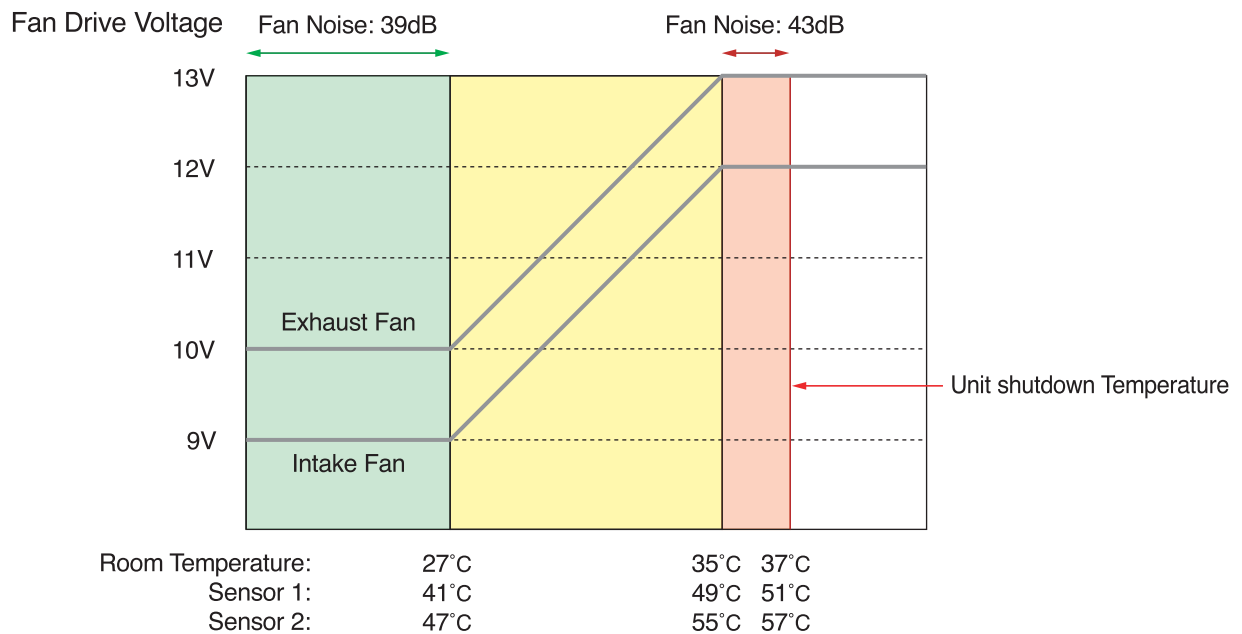

Fig. 1-9

# 5. CONNECTING

## 5.1 Connection to the computer

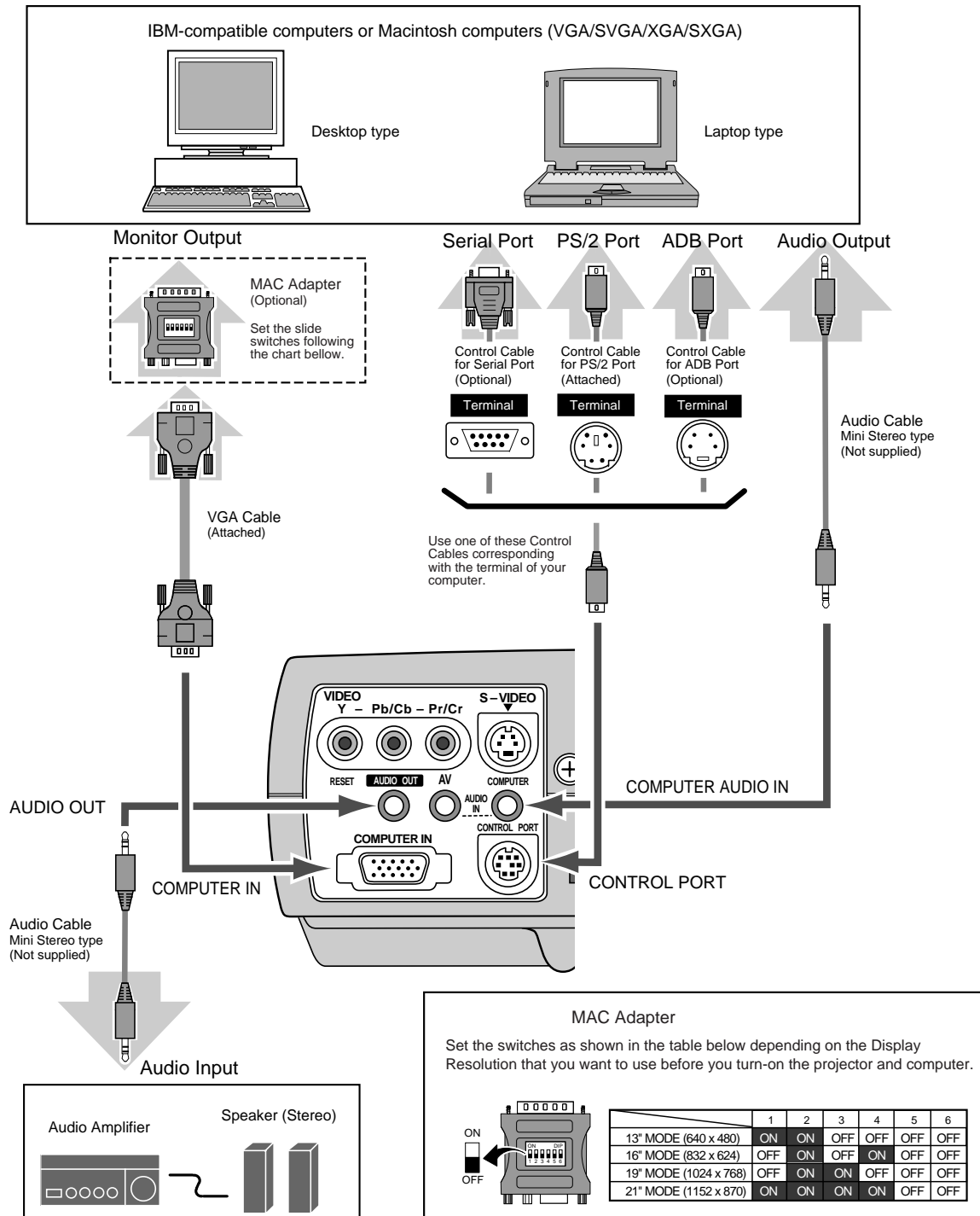

Fig. 1-10

## 5.2 Connecting to the video equipment

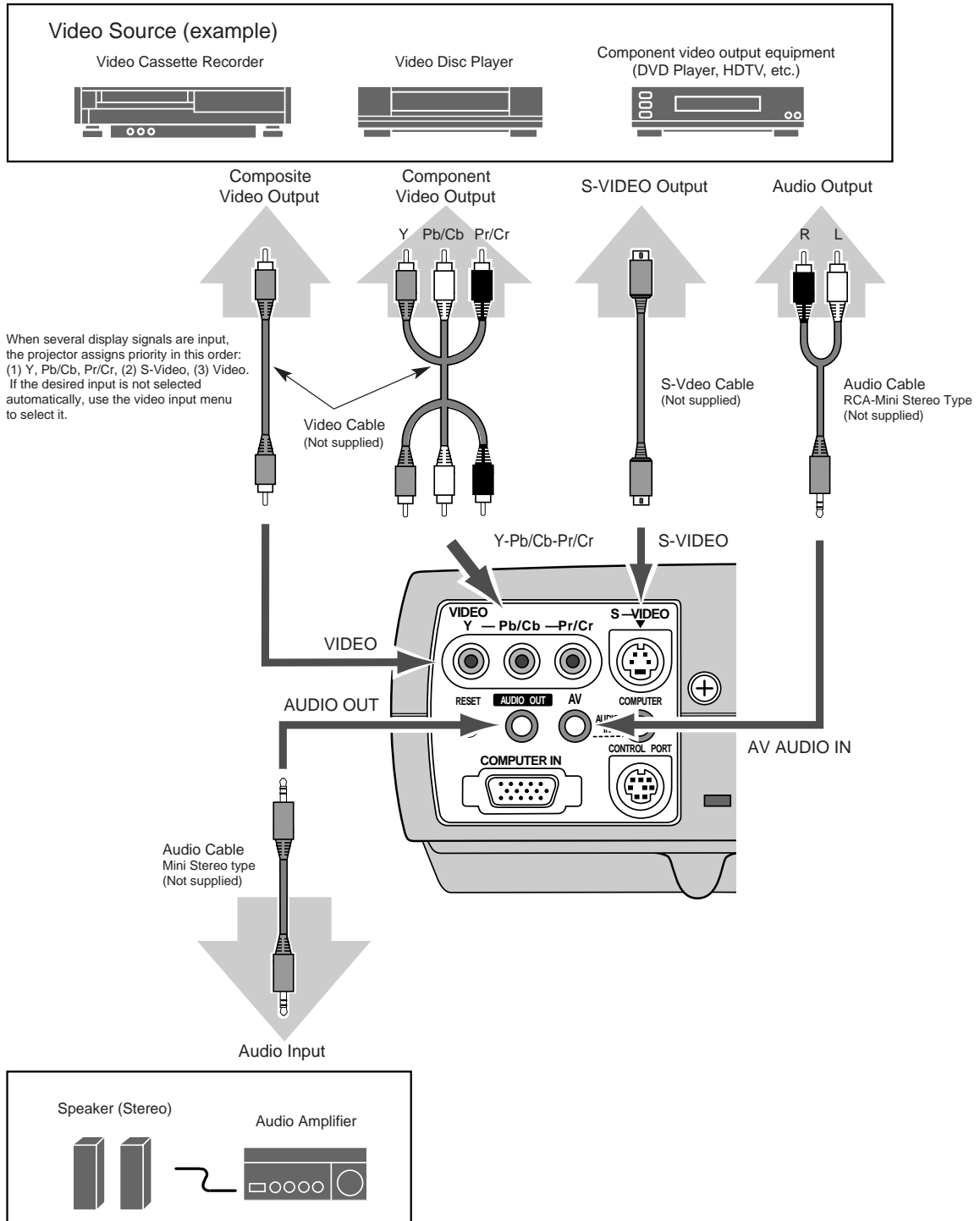
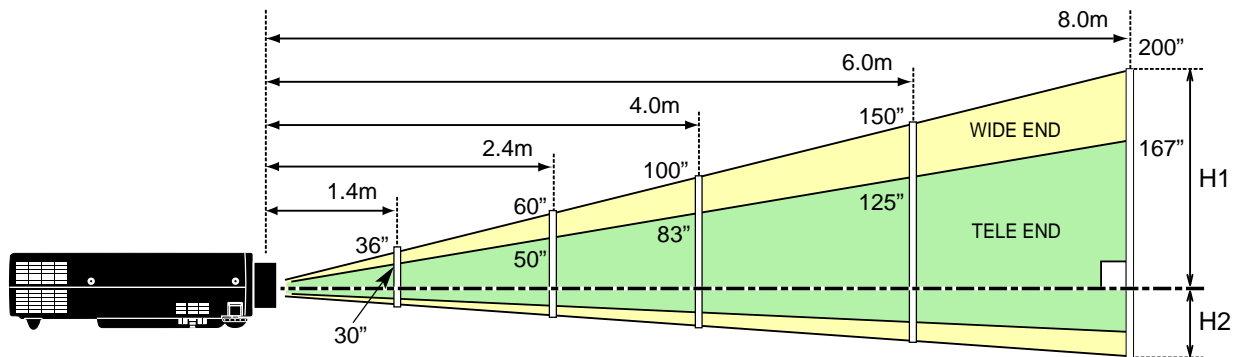

Fig. 1-11

## 6. SETTING-UP THE PROJECTOR

### 6.1 Positioning the projector

This projector is designed to project on a flat projection surface. The projector can be focused from 1.4m (4.6') to 8.0m (26.3'). Refer to the figure below to adjust the screen size.



Screen Size (W x H) mm	30"	60"	100"	150"	200"
	610 x 457	1219 x 914	2032 x 1524	3048 x 2286	4064 x 3048
Height (H1)	422mm	844mm	1407mm	2110mm	2814mm
Height (H2)	35mm	70mm	117mm	176mm	234mm

Fig. 1-12

### 6.2 Installation precautions

#### 1) Temperature of air discharged from exhaust vent

Hot air is discharged from the exhaust vent. Do not put the object in the way of this hot air.

#### 2) Installation site

Do not install the projector in humid or dusty locations, or locations subject to a lot of oil mist or cigarette smoke. Doing so may cause dirt to adhere to the lenses, mirrors and other optical parts, resulting in impaired image quality. Also, do not install the projector in high- or low-temperature locations.

#### 3) Operating temperature range: 5°C to 35°C

#### 4) Storage temperature range: -10°C to 60°C

#### 5) Condensation

Do not move the projector suddenly from a low-temperature location to a high-temperature location, or suddenly raise the room temperature. Doing so can cause moisture in the air to condense on the lenses and mirrors of the projector, resulting

in blurred images.

**6) Screen and room brightness**

Do not install the projector where sunlight or lighting directly strikes on the screen. If sunlight or light from lighting strikes on the screen, image will appear whitish and difficult-to-view.

## 7. SUPPORTED COMPUTER SYSTEM MODE

The projector judges the incoming signal from the connected personal computer and automatically selects the appropriate system mode. Some models cannot be selected depending on the computer. In this case, the message **Go to PC adj.** is displayed at the system box on the menu bar. (Adjust and set the computer system manually.)

Table 1-1

On-Screen Display	Resolution	H-Frequency (KHz)	V-Frequency (Hz)	On-Screen Display	Resolution	H-Frequency (KHz)	V-Frequency (Hz)
VGA 1	640 x 480	31.47	59.88	XGA 3	1024 x 768	60.023	75.03
VGA 2	720 x 400	31.47	70.09	XGA 4	1024 x 768	56.476	70.07
VGA 3	640 x 400	31.47	70.09	XGA 5	1024 x 768	60.31	74.92
VGA 4	640 x 480	37.86	74.38	XGA 6	1024 x 768	48.50	60.02
VGA 5	640 x 480	37.86	72.81	XGA 7	1024 x 768	44.00	54.58
VGA 6	640 x 480	37.50	75.00	XGA 8	1024 x 768	63.48	79.35
VGA 7	640 x 480	43.269	85.00	XGA 9	1024 x 768 (Interlace)	36.00	43.59
MAC LC13	640 x 480	34.97	66.60	XGA 10	1024 x 768	62.04	77.07
MAC 13	640 x 480	35.00	66.67	XGA 11	1024 x 768	61.00	75.70
RGB	—	15.734	30	XGA 12	1024 x 768 (Interlace)	35.522	43.48
RGB	—	15.625	25	XGA 13		46.90	58.20
SVGA 1	800 x 600	35.156	56.25	XGA 14	1024 x 768	47.00	58.30
SVGA 2	800 x 600	37.88	60.32	XGA15	1024 x 768	58.03	72.00
SVGA 3	800 x 600	46.875	75.00	MAC 19	1024 x 768	60.24	75.08
SVGA 4	800 x 600	53.674	85.06	MAC 21	1152 x 870	68.68	75.06
SVGA 5	800 x 600	48.08	72.19	SXGA 1	1152 x 864	64.20	70.40
SVGA 6	800 x 600	37.90	61.03	SXGA 11	1152 x 900	61.20	65.20
SVGA 7	800 x 600	34.50	55.38	SXGA 13	1280 x 1024 (Interlace)	50.00	43.00
SVGA 8	800 x 600	38.00	60.51	SXGA 14	1280 x 1024 (Interlace)	50.00	47.00
SVGA 9	800 x 600	38.60	60.31	SXGA 17	1152 x 900	61.85	66.00
SVGA 10	800 x 600	32.70	51.09	SXGA 18	1280 x 1024 (Interlace)	46.43	43.35
SVGA 11	800 x 600	38.00	60.51	HDTV720p	—	45.00	60.00
MAC1 6	832 x 624	49.72	74.55	HDTV1035i	—	33.75	60.00
XGA 1	1024 x 768	48.36	60.00	HDTV1080i	—	33.75	60.00
XGA 2	1024 x 768	68.677	84.997				

NOTE: Specifications are subject to change without notice.

When these signals (marked in yellow): XGA, SXGA, Mac16, Mac19, Mac21, HDTV720p, HDTV1035i, HDTV1080i, are projected there will be some difference in lines and characters because the signals are digitally compressed.

The dot clock is not compatible with computer signals higher than 100MHz.





***Part 2***

---

***Repair  
Information***



# 1. SAFETY INSTRUCTIONS

**WARNING:**

The chassis of this projector is isolated (COLD) from AC line by using the converter transformer. Primary side of the converter and lamp power supply unit circuit is connected to the AC line and it is hot, which hot circuit is identified with the line (  ) in the schematic diagram. For continued product safety and protection of personnel injury, servicing should be made with qualified personnel.

The following precautions must be observed.

- 1: An isolation transformer should be connected in the power line between the projector and the AC line before any service is performed on the projector.
- 2: Comply with all caution and safety-related notes provided on the cabinet back, cabinet bottom, inside the cabinet or on the chassis.
- 3: When replacing a chassis in the cabinet, always be certain that all the protective devices are installed properly, such as, control knobs, adjustment covers or shields, barriers, etc.

**DO NOT OPERATE THIS PROJECTOR WITHOUT THE PROTECTIVE SHIELD IN POSITION AND PROPERLY SECURED.**

- 4: Before replacing the cabinet cover, thoroughly inspect the inside of the cabinet to see that no stray parts or tools have been left inside.

Before returning any projector to the customer, the service personnel must be sure it is completely safe to operate without danger of electric shock.

Product safety should be considered when a component replacement is made in any area of the projector. Components indicated by mark  in the parts list and the schematic diagram designate components in which safety can be of special significance. It is, therefore, particularly recommended that the replacement of these parts must be made by exactly the same parts.

Eye damage may result from directly viewing the light produced by the Lamp used in this equipment. Always turn off Lamp before opening cover. The Ultraviolet radiation eye protection required during this servicing.

Never turn the power on without the lamp to avoid electric-shock or damage of the devices since the stabilizer generates high voltages (15kV - 25kV) at its starts.

Since the lamp is very high temperature during units operation replacement of the lamp should be done at least 45 minutes after the power has been turned off, to allow the lamp cool-off.

## 2. CIRCUIT PROTECTIONS

This projector is equipped with the following circuit protections to operate in safety. If the abnormality occurs inside the projector, it will automatically turn off by operating one of the following protection circuits.

### 2.1 Fuse

The fuse is located inside of the projector. When either the LAMP indicator or the READY indicator is not illuminated, fuse may be opened. Check the fuse as following steps. It should be used the specified fuse as follows;

**Fuse Part No.: CY2-8376-000  
TYPE T4.0AH 250V FUSE  
LITTEL FUSE INC. TYPE 215004**

#### [How to replace the fuse]

1. Remove the cabinet top and main board following to “Mechanical Disassemblies”.
  2. Remove a screw and the line filter cover upward.
  3. Remove the fuse from fuse holder.
- To install the fuse, take reversed step in the above.

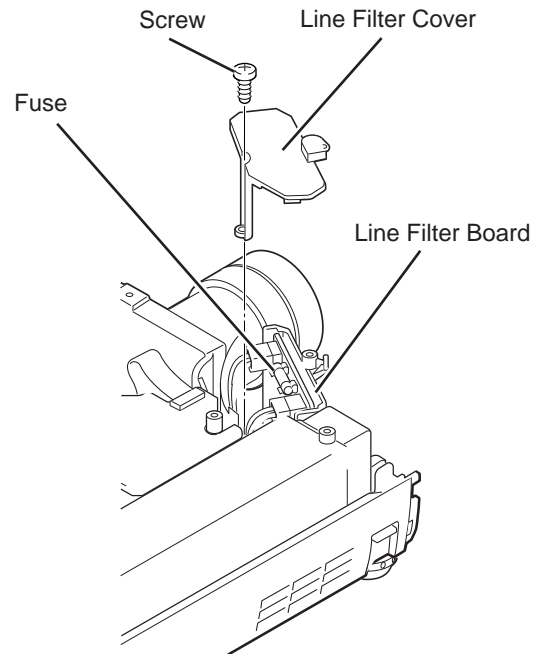

Fig. 2-1

### 2.2 Thermal Switch

There is the thermal switch (SW902) inside of the projector to prevent the internal temperature from rising abnormally. When the internal temperature reaches near 100°C, turn off the AC main power supply automatically. The thermal switch is not reset to normal automatically even if the internal temperature becomes normal. Reset the thermal switch following procedure.

Check the resistance between terminals of thermal switch by using the tester. If it has high impedance, thermal switch may be in operative.

#### [How to reset the thermal switch]

1. Remove the cabinet top following to “Mechanical Disassemblies”.
2. Press the reset button on the thermal switch.

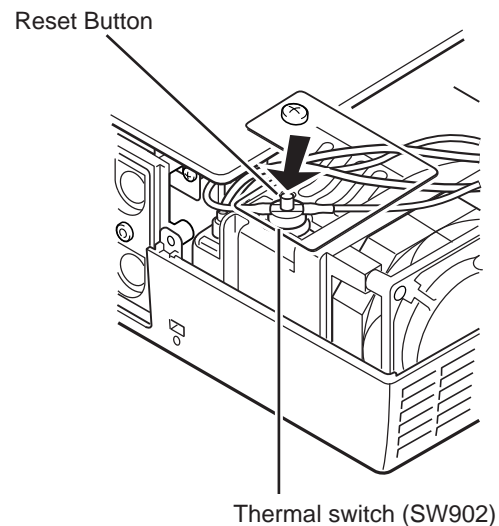

Fig. 2-2

**CAUTION**

Before press the reset button, disconnect the AC cord from the projector.

## 2.3 Warning Temperature and Power Failure Protection

The TEMP WARNING indicator flashes red and the projector will automatically turn off when the internal temperature of the projector exceeds the normal temperature or when stopping cooling fans or when the internal power supply lines are failed.

Check the following possible causes and wait until stopping the TEMP WARNING indicator flashing.

### Possible causes

- Air filter is clogged with dust particles. Remove dust from the air filter by following instructions in the “Air filter care and cleaning” below.
- Ventilation slots of the projector are blocked. In such an event, reposition the projector so that ventilation slots are not obstructed.
- Check if projector is used at higher temperature place (Normal operating temperature is 5 to 35 °C or 41 to 95 °F)

If the TEMP WARNING indicator still continues to flash, there may be defects on cooling fans or power supply circuits. Please check fan operation and power supply lines referring to the “Power Supply Lines Chart”.

## 2.4 Air Filter Care and Cleaning

The removable air filters prevents dust from accumulation on the surface of the projection lens and projection mirror. Should the air filter become clogged with dust particles, it will reduce the cooling fan’s effectiveness and may result in internal heat build up and reduce the life of the projector.

To clean up the air filters, follow the cleaning procedure below:

1. Turn the power off, and disconnect the AC power cord from the AC outlet.
2. Turn the projector up side down and remove 2 air filters (Large and Small) by pulling the latches of them upward.
3. Clean the air filters with brush or wash out the dust and particles.
4. Replace each air filter properly. Make sure that the air filters are fully inserted.

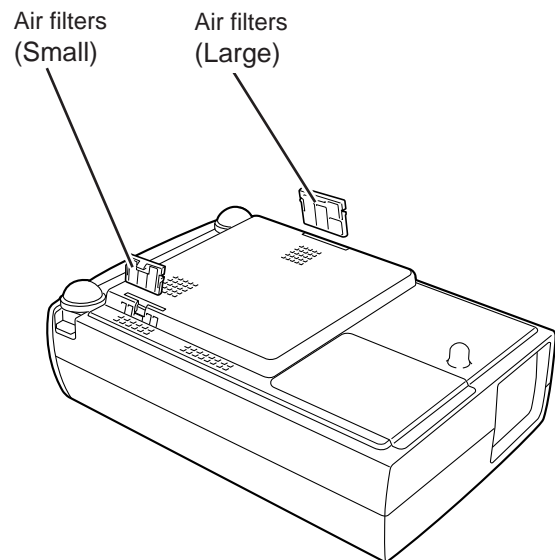

Fig. 2-3

Do not operate the projector with the air filter removed. The dust is stuck on the LCD panel and the mirror, and it may spoil the fine picture image.

Do not put the small parts into the air filter intake vents. It result in the malfunction of the projector. The air filter is small parts. Take care that children don't eat or swallow it.

**CAUTION**

We recommend to avoid dusty, smoky place for operating the projector. Using in dusty place may cause the picture of poor quality.

When using under the dusty or smoky conditions, dust may accumulate on the LCD panel and lens inside it, and may resultantly be projected on the screen together with the picture.

When the above symptoms are noticed, please clean up the LCD panel and lens following to the "Cleaning Method".

## 3. MECHANICAL DISASSEMBLIES

Mechanical disassemble should be made following procedures in numerical order. Following steps show the basic procedures, therefore unnecessary step may be ignored.

### CAUTION

The parts and screws should be placed exactly the same position as the original otherwise it may cause loss of performance and product safety.

### 3.1 Cabinet Top Removal

- (1) Remove 5 screws.
- (2) Remove 2 screws A of the Cabinet Front (bottom part). See Fig. 2-5
- (3) Pull the lower part of the Cabinet Front off forward.
- (4) Pull the Cabinet Top upward while opening the arrow indicated part of it toward outside.

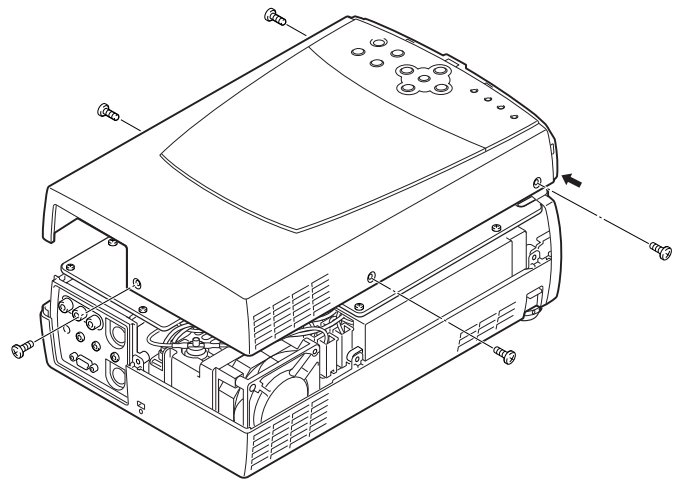

Fig. 2-4

### 3.2 Cabinet Front and Speaker Removal

1. Remove 4 screws (2 top and 2 bottom) A and take the cabinet front off forward.
2. Remove 2 screws B and then remove RC board and temp board.
3. Remove 4 screws C and the speaker.

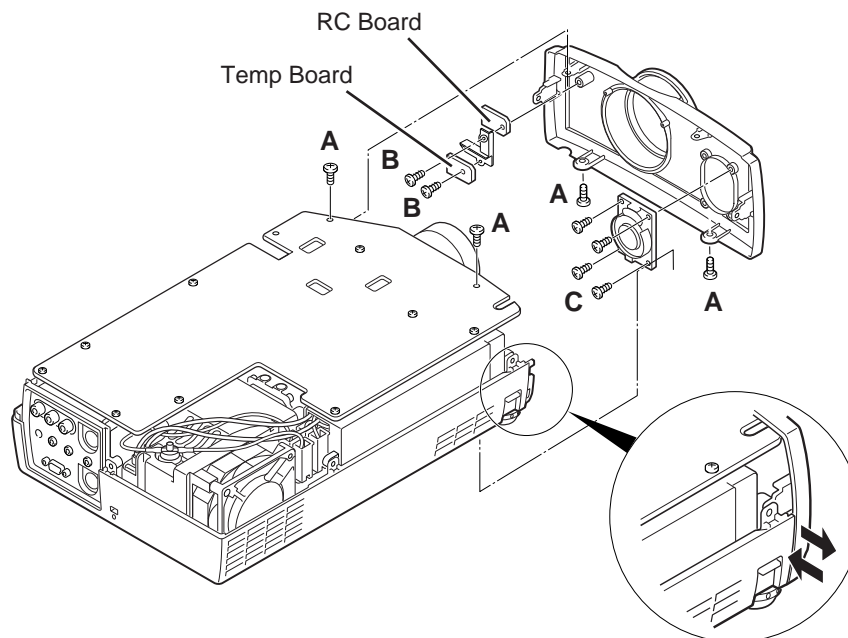

Fig. 2-5

### 3.3 Main Board Removal

1. Remove 9 screws and remove the main board upward.

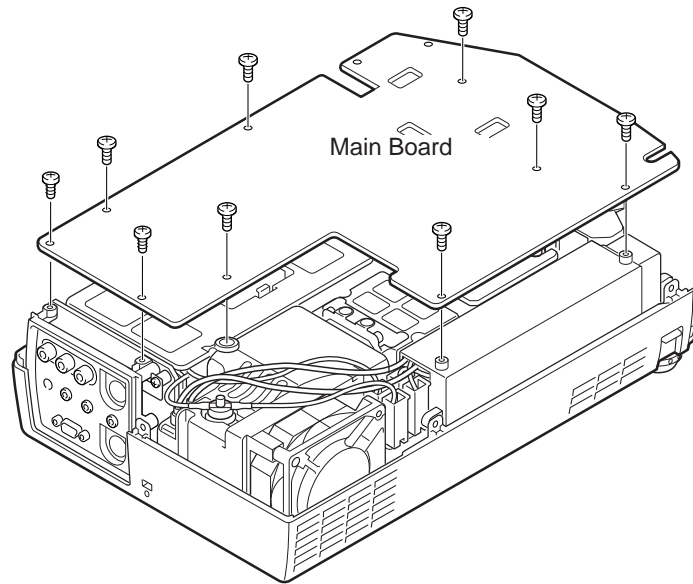

Fig. 2-6

### 3.4 Fuse Removal

1. Remove a screw and pull the line filter cover upward and then replace the fuse if required.

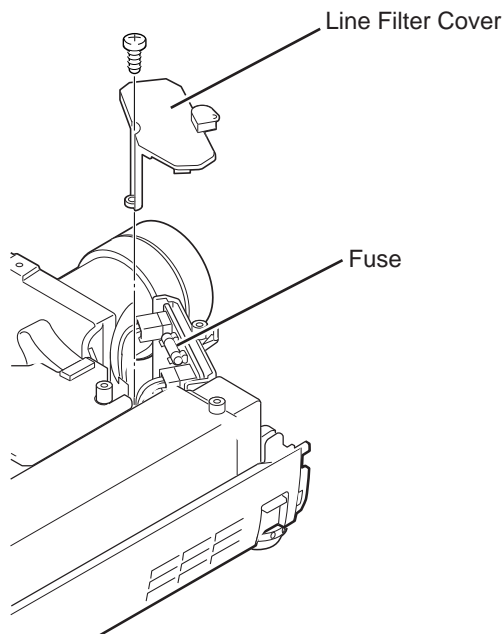

Fig. 2-7



### 3.5 AV and Component Board Removal

1. Remove 3 screws **A** and FPC cables, and then take the component board off upward.
2. Remove a screw **B** and a grounding lead, and then take the AV board ass'y off upward.

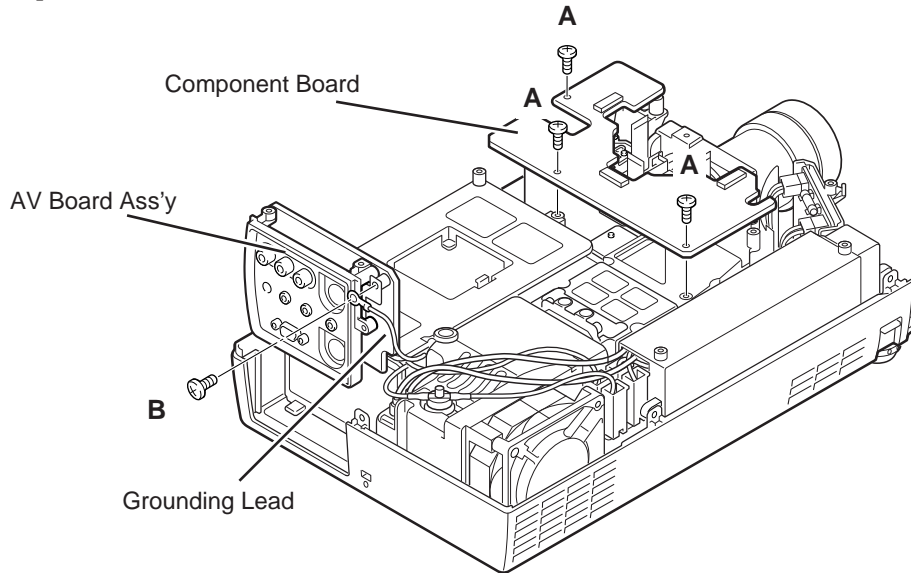

Fig. 2-8

### 3.6 Line Filter Board Removal

1. Remove a screw **A** and remove a grounding lead.
2. Remove 2 screws **B** and take the line filter ass'y off upward.
3. Remove the line filter board from line filter holder.

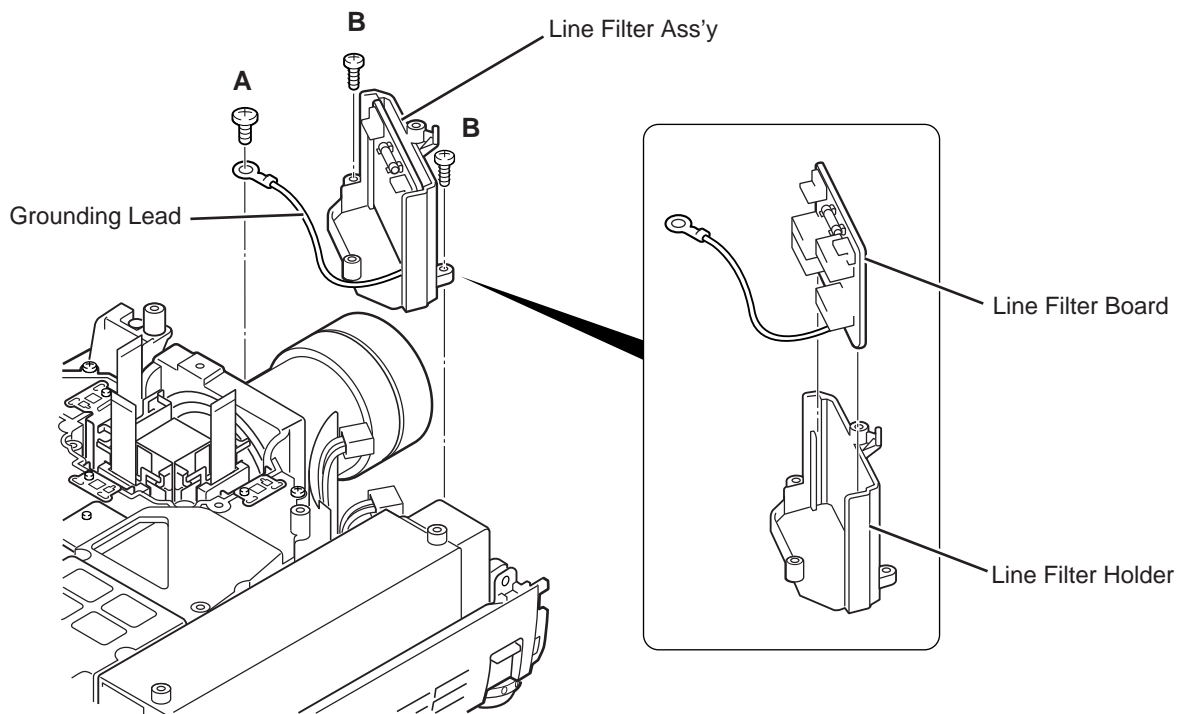

Fig. 2-9

### 3.7 Lamp Ballast Unit Fan (FN905) Removal

1. Disconnect the thermal switch sockets.
2. Remove a screw **A** and disconnect the lamp socket.
3. Remove 2 screws **B** (bottom side) and a screw **C**, and then remove the lamp ballast unit upward.
4. Take the cover off from the lamp ballast unit and remove 4 screws **D** and take the lamp ballast board off from the holder.
5. Remove the fan FN905 from the holder.

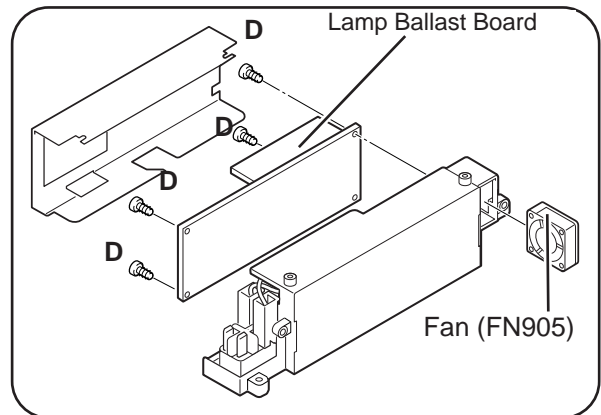
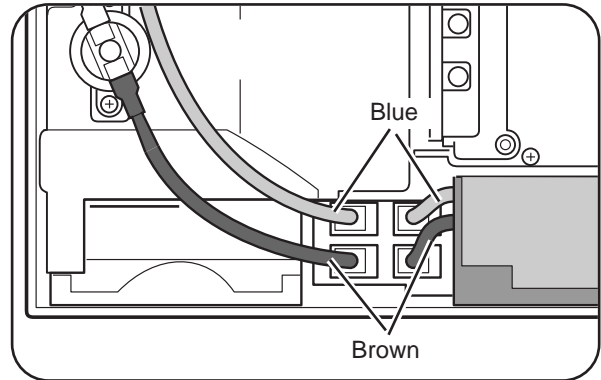
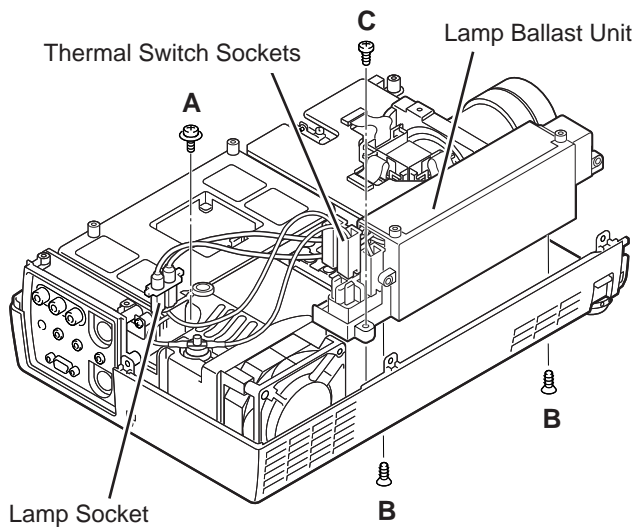

Fig. 2-10

### 3.8 Power Board Removal

1. Remove 2 screws **A** and take the power unit cover off upward.
2. Remove 3 screws **B** and pull the power board upward..

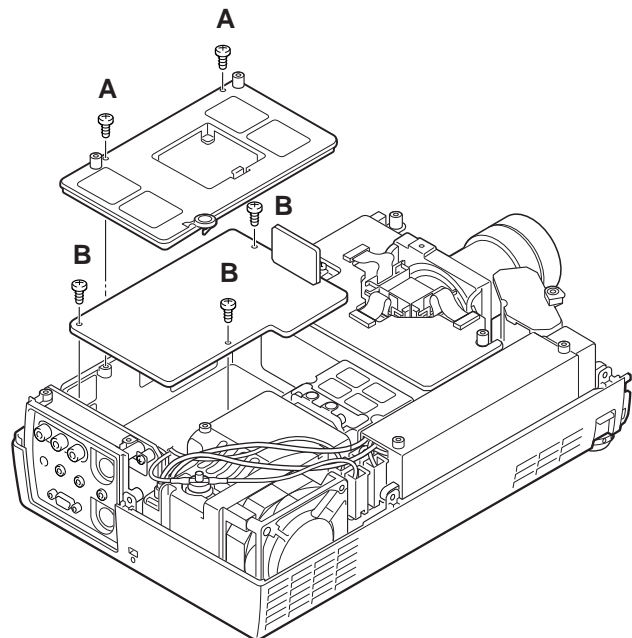

Fig. 2-11

### 3.9 Optical Unit and Fan (FN901) Removal

1. Remove 2 screws **A** and the thermal switch.
2. Remove a screw **B** and disconnect the lamp socket.
3. Remove 7 screws **C** and pull the optical unit upward.
4. Remove 2 screws **D** and fan (FN901).

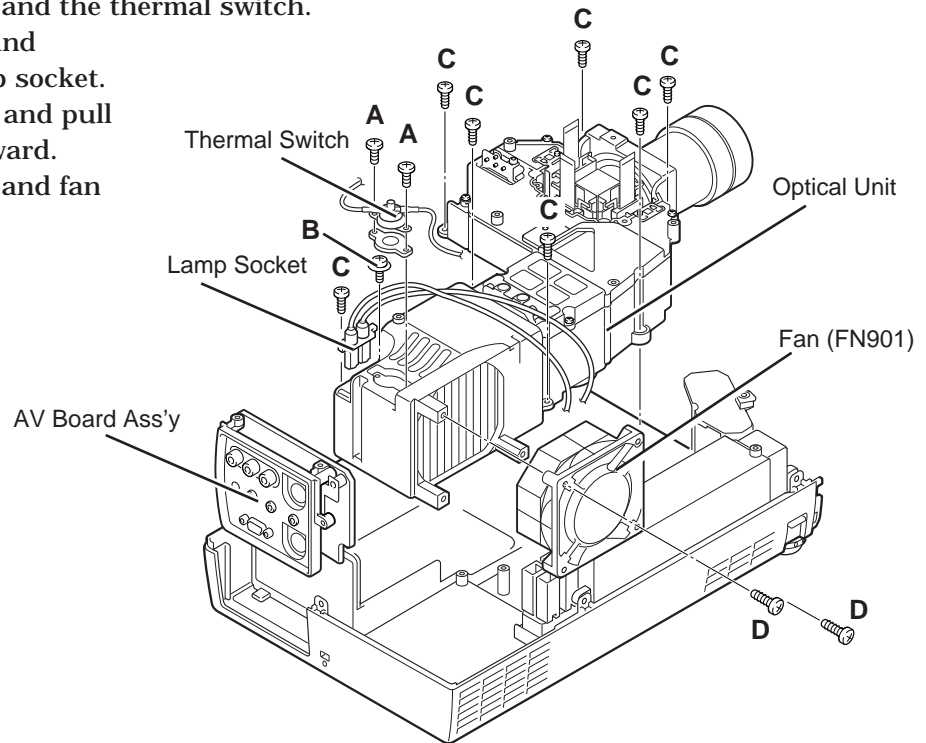

Fig. 2-12

### 3.10 Audio Amp. Board Removal

1. Remove a screw **A** (bottom side) and 2 screws **B**, and then pull the power unit holder upward.
2. Remove 2 screws **C** and take the audio amp. board off from the power unit holder.

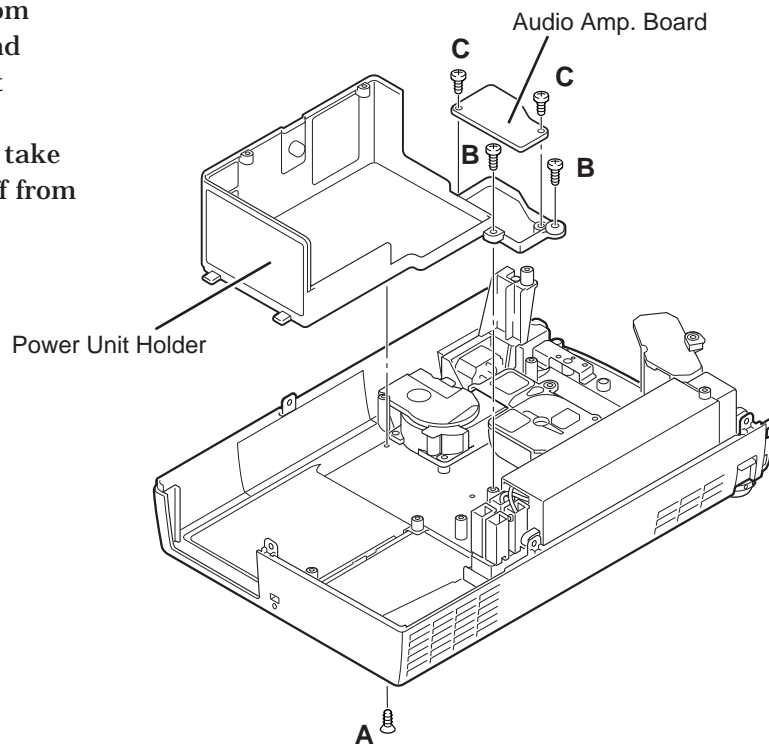

Fig. 2-13

### 3.11 Fans (FN902, FN903, FN904) Removal

1. Remove 4 screws **A** and 3 screws **B** and remove the duct cover and fans (FN902 and FN903).
2. Remove 2 screws **C** and fan (FN904), and remove 2 screws **D** and fan holder.

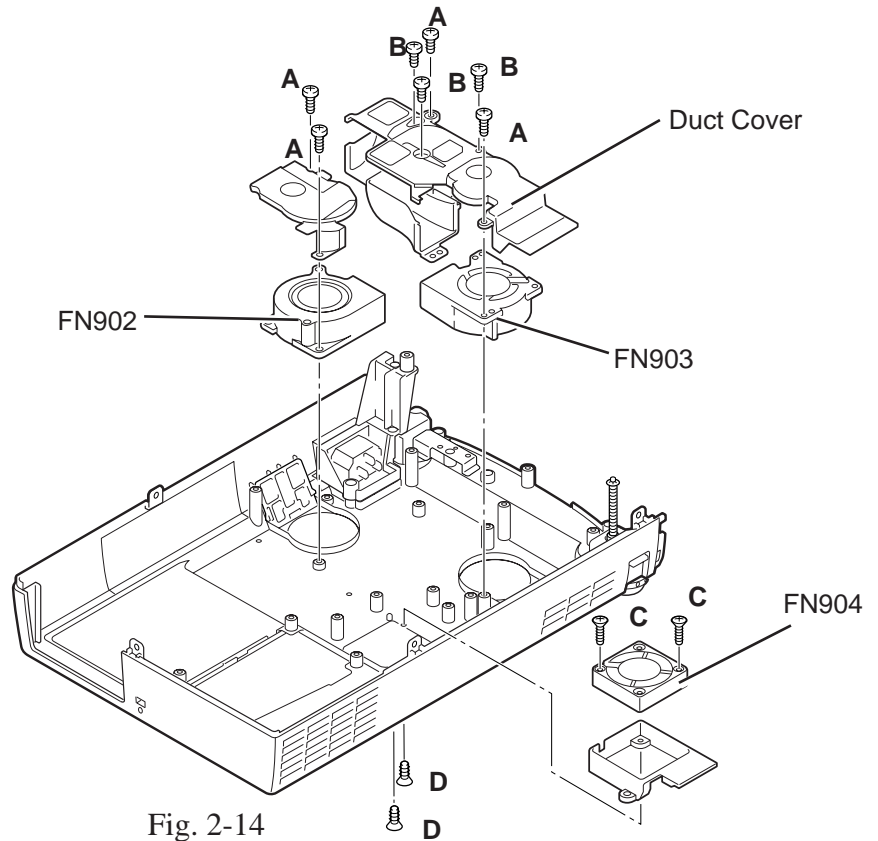

Fig. 2-14

### 3.12 AC Inlet Ass'y Removal

1. Remove a screw **A** and a grounding lead.
2. Remove 2 screws **B** and pull the AC inlet ass'y upward.

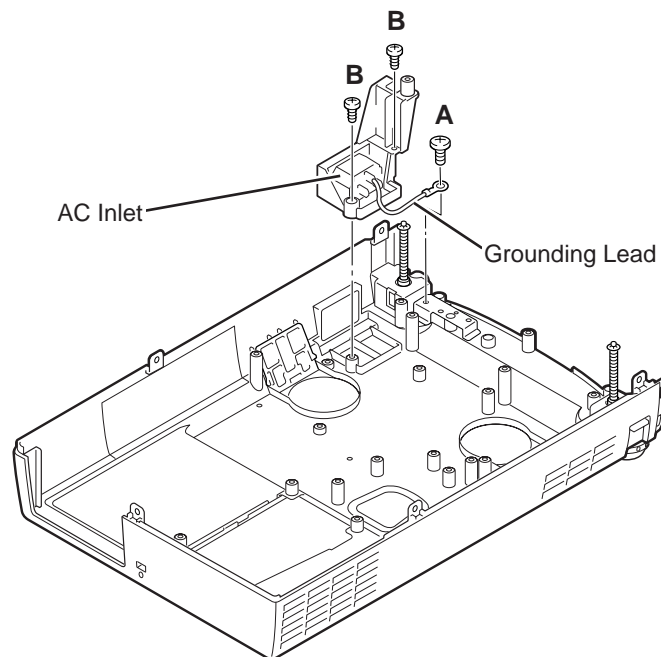

Fig. 2-15

## 4. OPTICAL PARTS DISASSEMBLIES

### 4.1 Projection Lens Removal

1. Remove the Cabinet top and cabinet front following to “Mechanical Disassemblies”.
2. Remove 4 screws and remove the Projection Lens.

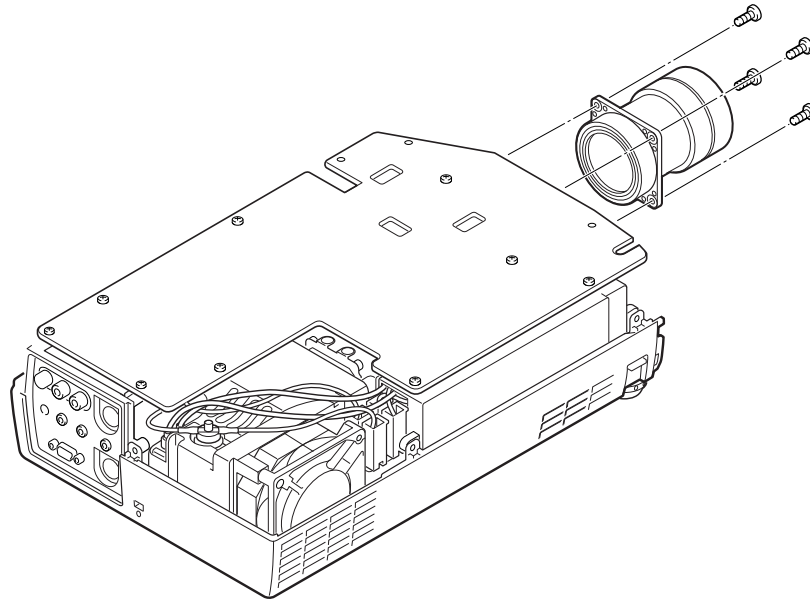

Fig. 2-16

### 4.2 Optical Unit Top Removal

1. Remove the Cabinet top, front, main board, component boards and power unit cover following to “Mechanical Disassemblies”.
2. Remove 6 screws and take the optical unit top off upward.

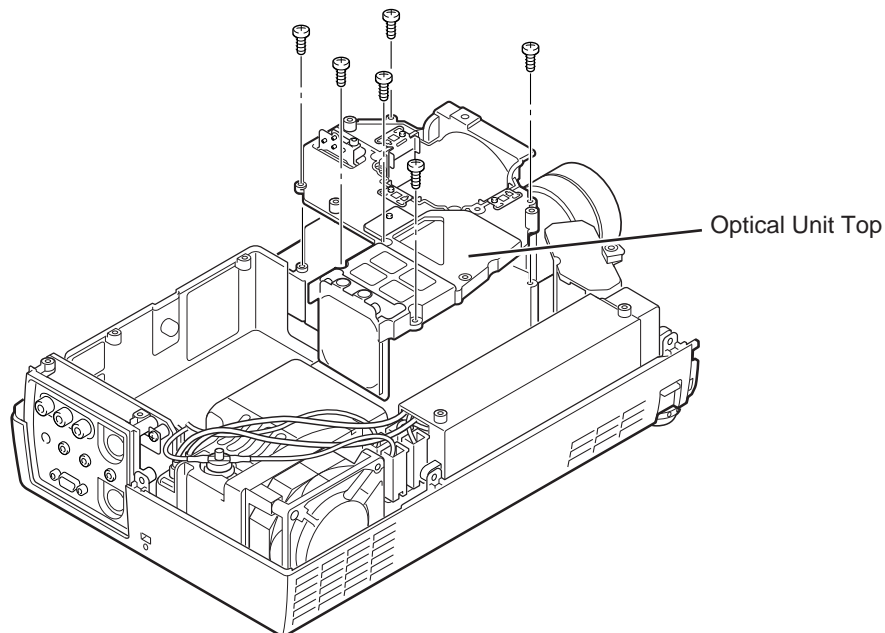

Fig. 2-17

### 4.3 Integrator Lens Ass'y Disassembly

1. Remove the cabinet top, front and main board following to "Mechanical Disassemblies".
2. Remove 2 screws **A** and take the integrator lens ass'y off upward.
3. Release 4 hooks **B** on the holder and remove the integrator lens.

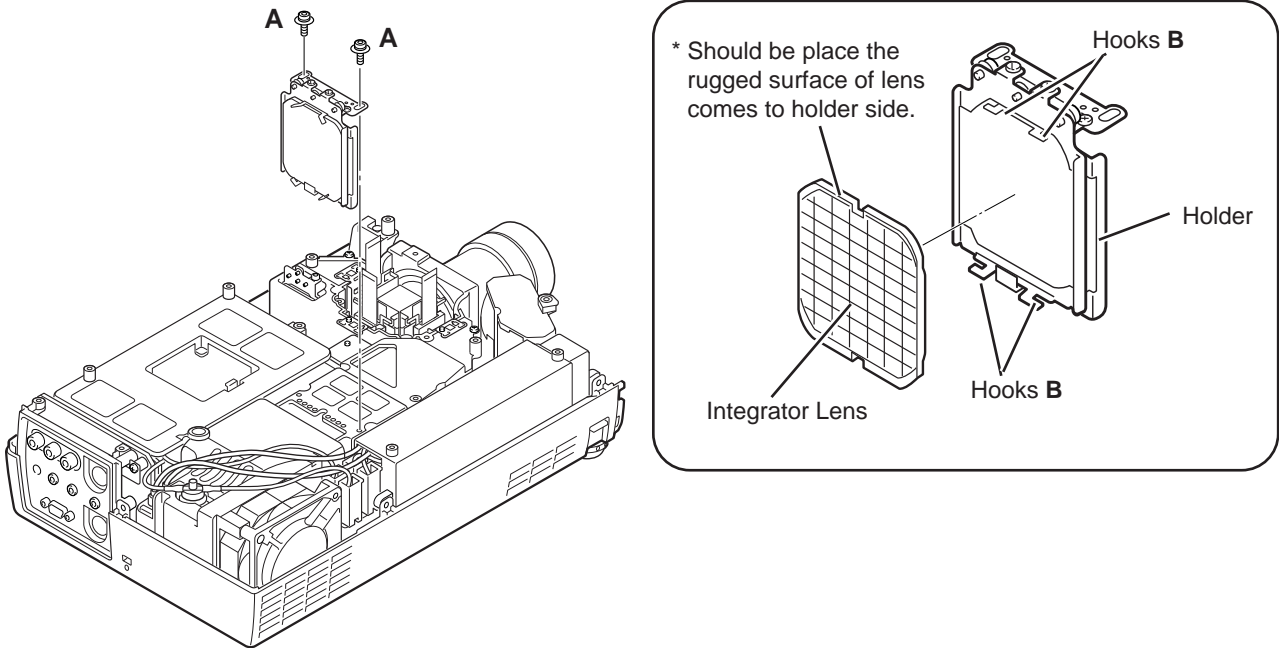

Fig. 2-18

### 4.4 Relay Lens Ass'y Disassembly

1. Remove the cabinet top, front, main and component boards following to "Mechanical Disassemblies".
2. Remove 2 screws **A** and take the relay lens ass'y off upward.
3. Remove 2 screws **B** on the holder and take the relay lens off.

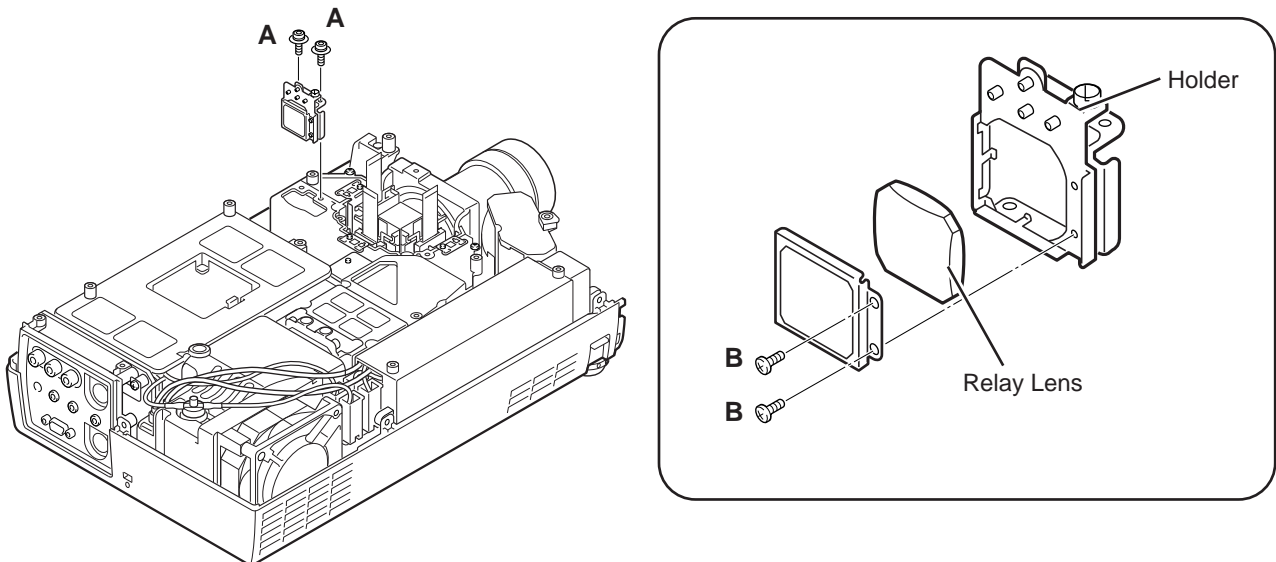

Fig. 2-19

### 4.5 Polarized Glass-in Ass'y Disassembly

1. Remove the cabinet top, front, main and component boards following to "Mechanical Disassemblies".
2. Remove each screw and take the each polarized glass-in ass'y off upward.
3. Release 2 hooks and remove the polarized glass-in.

Note:  
Each polarized glasses are different parts.

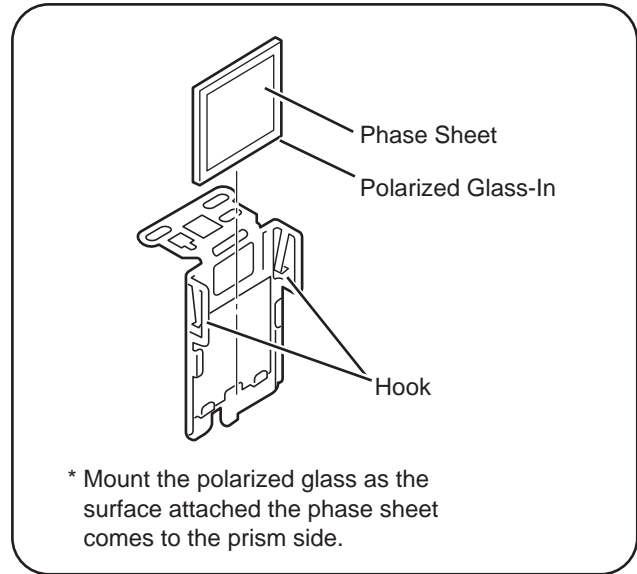
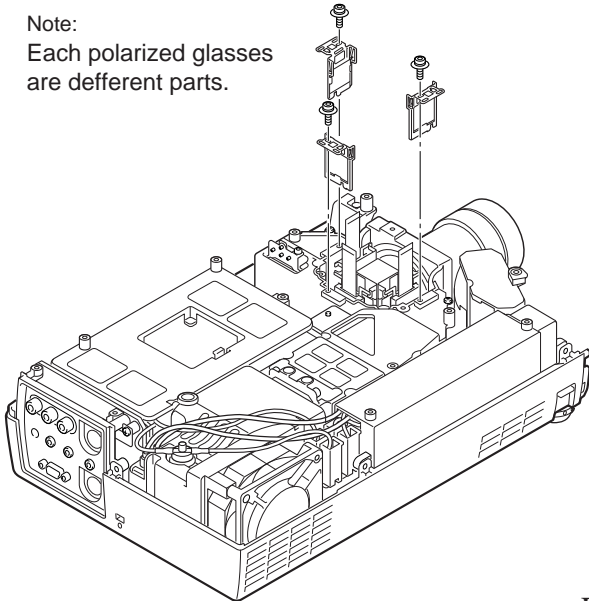

Fig. 2-20

### 4.6 Polarized Glass-out Ass'y Disassembly

1. Remove the cabinet top, front and main boards following to "Mechanical Disassemblies".
2. Remove 4 screws by using the 2.0 mm hex driver and take the LCD Panel/Prism ass'y off upward from the optical unit.
3. Remove each screw and take the each polarized glass-out off upward.

Note:  
Do not replace the LCD panel separately otherwise it can not obtain proper picture.

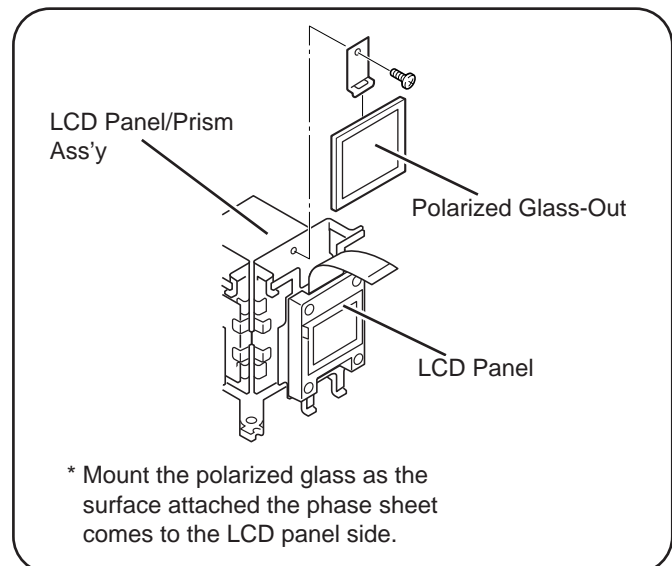
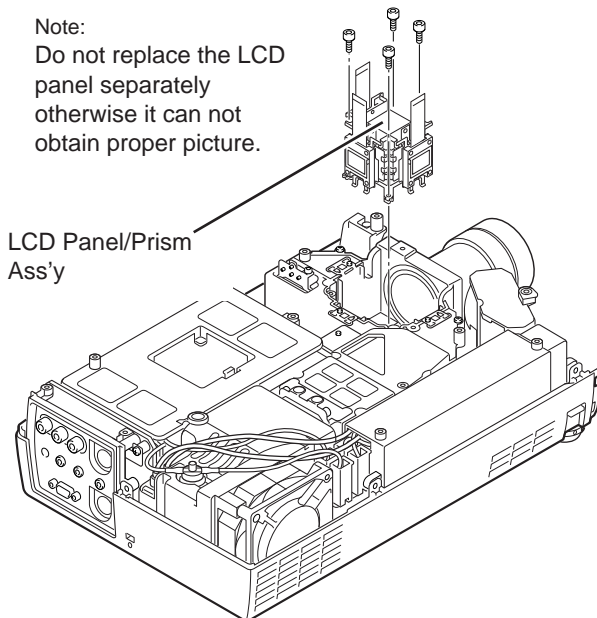

Fig. 2-21



### 4.7 Locations and Directions

When the optical parts mounting or assembling, the parts must be mounted in the specified location and direction. Please follow to the figure below.

No.	Part name	No.	Part name
1	Prism ass'y	12	Relay lens (OUT)
2	Integrator lens (IN)	13	Relay lens (IN)
3	Integrator lens (OUT)	14	Dichroic mirror (G)
4	Prism Ass'y (PBS)	15	Condenser lens
5	Condenser lens (OUT)	16	Polarized glass (OUT/R)
6	Dichroic mirror (R)	17	Polarized glass (OUT/G)
7	Mirror (R)	18	Polarized glass (OUT/B)
8	Condenser lens (R)	19	Polarized glass (IN/R)
9	Condenser lens (B)	20	Polarized glass (IN/G)
10	Mirror (B)	21	Polarized glass (IN/B)
11	Optical Filter (UV cut)		

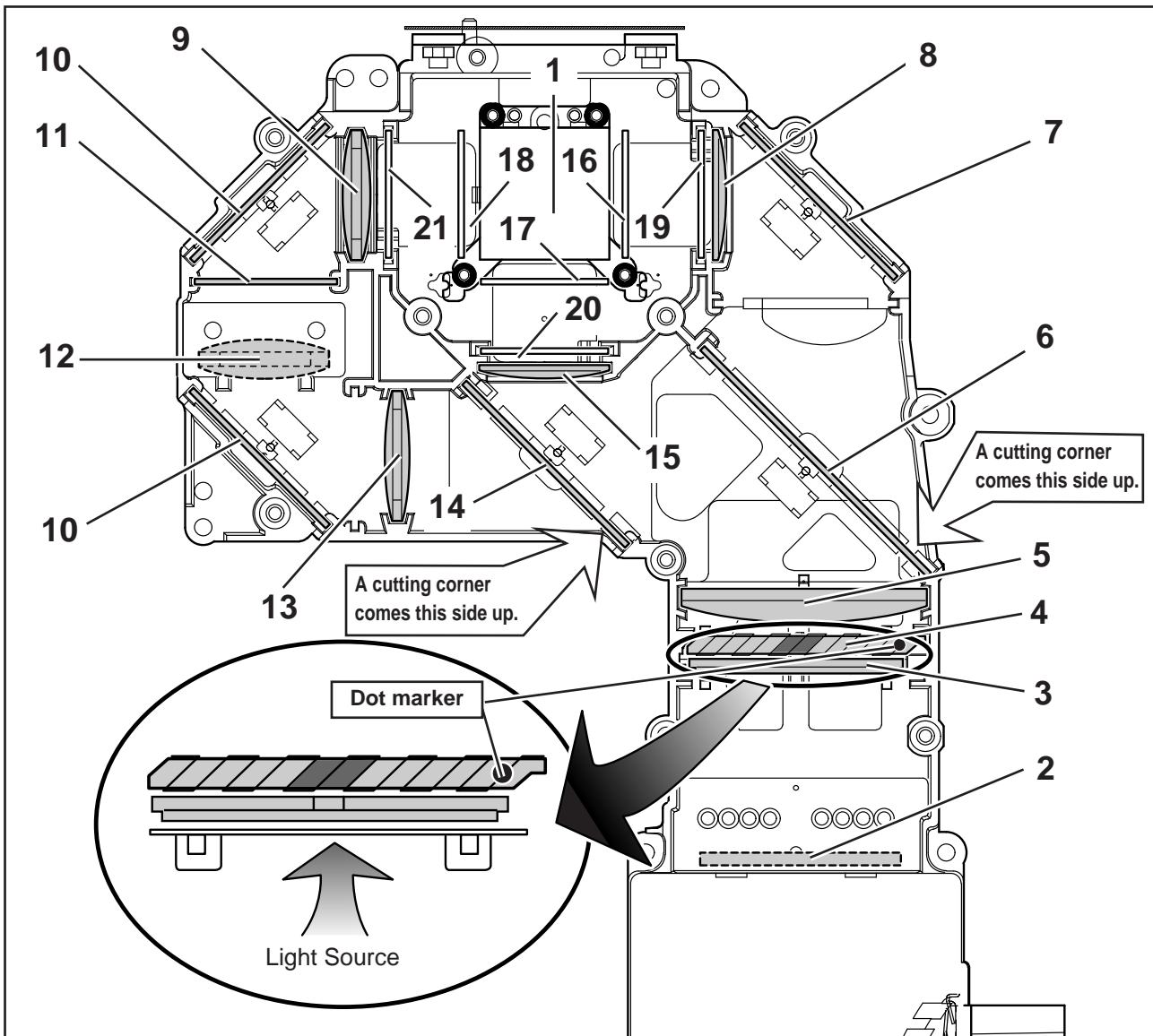

Fig. 2-22



## 5. LCD PANEL/PRISM ASS'Y REPLACEMENT

LCD panels used for this model can not be replaced separately. Do not disassemble the LCD Panel/Prism Ass'y. These LCD panels are installed with precision at the factory. When replacing the LCD panel, should be replaced whole of the LCD panels and prism ass'y at once. After replacing LCD Panel/Prism ass'y, please check the following adjustments.

### WARNING

- Check the “Integrator Lens Adjustment” and “Relay Lens Adjustment” following to chapter “Optical Adjustment”.
- Check the “White Balance Adjustment” and “Black Balance Adjustment” following to chapter “Electrical Adjustment”.
- Check the white uniformity on the screen.
- If you find the color shading, please adjust the white uniformity by using the proper computer and “Color Shading Correction” software attached with this manual.

**COLOR SHADING CORRECTION** (Ver. 2.0.2)

### 5.1 LCD Panel/Prism Ass'y Removal

1. Remove the cabinet top, front and main board following to “Mechanical Disassemblies”.
2. Remove 4 screws by using the 2.0 mm hex driver and take the LCD Panel/Prism ass'y off upward from the optical unit.

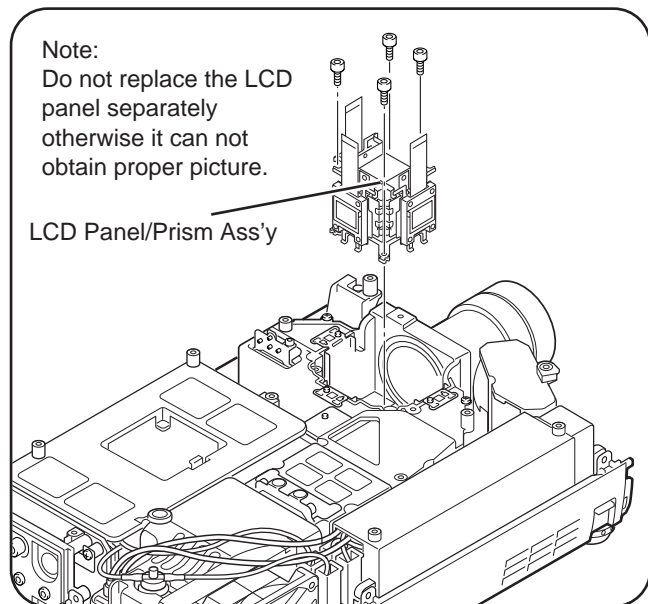

Fig. 2-23

## 5.2 Note on LCD Panel/Prism Ass'y Mounting

After replacing or installing the LCD Panel/Prism ass'y, please make sure to obtain the best focus in both TELE and WIDE zoom. If the focus adjustment is required, please adjust the positioning of LCD Panel/Prism Ass'y by following the below procedure.

### Mounting Procedure

1. Loosen 4 screws **A** on the LCD Panel/Prism ass'y with 2.0 mm hex driver.
2. Turn the projector on and project the image with WIDE zoom, and adjust the FOCUS control to obtain the best focus.
3. Turn the ZOOM control to the TELE position.
4. Move the LCD Panel/Prism Ass'y backward or forward (about 0mm - 0.8mm) to obtain the proper focus. Confirm the focus at TELE and WIDE zoom.
5. Tighten 4 screws **A** to fix the LCD Panel/Prism ass'y.

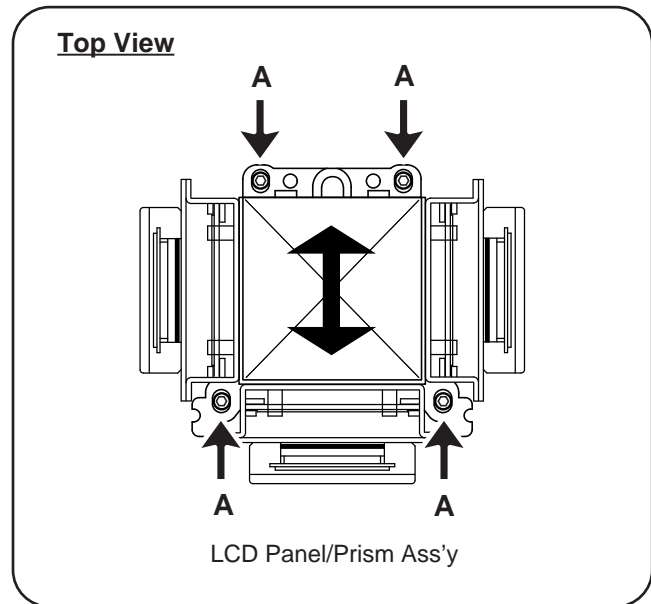

Fig. 2-24

## 6. CLEANING

### WARNING

After long periods of use, dust and other particles will accumulate on the LCD panel, prism, mirror, polarized glass, lens, etc., causing the picture to darken or color to blur. If this occurs, clean the inside of optical unit.

Remove dust and other particles using air spray. If dirt cannot be removed by air spray, disassemble and clean the optical unit.

### Cleaning with air spray

1. Remove the cabinet top following to “Mechanical Disassemblies”.
2. Clean up the LCD panel and polarizing plate by using the air spray from the cabinet top opening.

### CAUTION

Use a commercial (inert gas) air spray designed for cleaning camera and computer equipment. Use a resin-based nozzle only. Be very careful not to damage optical parts with the nozzle tip. Never use any kind of cleanser on the unit. Also, never use abrasive materials on the unit as this may cause irreparable damage.

### Disassembly cleaning

Disassembly cleaning method should only be performed when the unit is considerably dirty and cannot be sufficiently cleaned by air spraying alone.

Be sure to readjust the optical system after performing disassembly cleaning.

1. Remove the cabinet top and main units following to “Mechanical Disassemblies”.
2. Remove the optical base top following to “Optical Unit Disassemblies”. If the LCD panel needs cleaning, remove the LCD panel unit following to “LCD panel replacement”.
3. Clean the optical parts with a soft cloth. Clean extremely dirty areas using a cloth moistened with alcohol.

### CAUTION

The surface of the optical components consists of multiple dielectric layers with varying degrees of refraction. Never use organic solvents (thinner, etc.) or any kind of cleanser on these components.

Since the LCD panel is equipped with an electronic circuit, never use any liquids (water, etc.) to clean the unit. Use of liquid may cause the unit to malfunction.

## 7. LAMP REPLACEMENT

### WARNING

- For continued safety, replace with a lamp assembly of the same type.
- Allow the projector to cool for at least 45 minutes before you open the lamp cover. The inside of the projector can become very hot.
- Do not drop the lamp module or touch the glass bulb! The glass can shatter and cause injury.

### Procedure

1. Turn off the projector and disconnect the AC cord. Allow the projector to cool for at least 45 minutes.
2. Remove a screw with a screwdriver and remove the lamp cover.
3. Remove 2 screws and pull out the lamp assembly by grasping the handle.
4. Replace the lamp assembly securely and tighten 2 screws.
5. Place the lamp cover and tighten a screw.
6. Connect the AC cord to the projector and turn on.
7. Reset the lamp replacement monitor timer, see below explanation.

**Service Parts No.: DY4-6108-000**  
**Description: Lamp A'ssy LV-LP10**

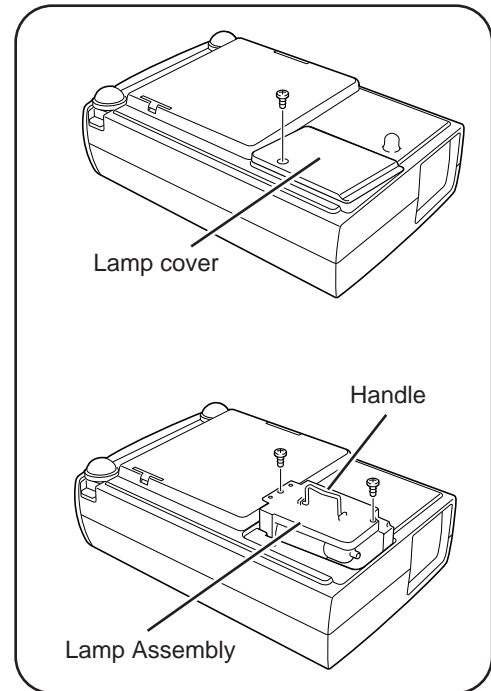

Fig. 2-25

### CAUTION

- Do not reset the Lamp Replacement Monitor Timer, except after the lamp is replaced.
- The projector can not be turned-on with the lamp cover removed, because when the lamp cover is removed, the interlock switch is also released to switch off the mains power for safety.

### How to reset the lamp replacement monitor timer

1. Turn the projector on, and press the MENU button and the ON-SCREEN MENU will appear. Press the POINT LEFT/RIGHT buttons to select SETTING and press the SELECT button. Another dialog box SETTING MENU will appear.
2. Press the POINT DOWN button and a red arrow icon will appear. Move the arrow to "Lamp age", and then press the SELECT button. The message "Lamp replace monitor Reset?" is displayed.
3. Select [Yes] to reset the Timer.

Please refer to the owners manual for further information.

### Recommendation

Should the air filter become clogged with dust particles, it will reduce the cooling fan's effectiveness and may result in internal heat build up and short lamp life. We recommend cleaning the air filter after the projection lamp is replaced.

Refer to "Air Filter Cleaning".

### How to check the accumulated illumination time

The LAMP REPLACEMENT indicator will illuminate when the accumulated illumination time of the lamp reaches 1000 hours. This is to indicate that lamp replacement is required.

You can check the accumulated illumination time of the lamp by following procedure.

1. Press and hold the pointer  on the projector for more than 20 seconds.
2. The accumulated illumination time is displayed on the right bottom corner of the screen. For example, when "Lamp Age 123 hours" is displayed, the accumulated illumination time of the lamp is 123 hours. This will disappear in 5 seconds.



Accumulated Illumination Time



***Part 3***

---

***Adjustment***





## 1. BEFORE ADJUSTMENTS

IC302 on the main board stores the data for the service adjustments, and should not be replaced except for the case of defective device. If replaced, it should be performed the re-adjustments following to the “Electrical Adjustments”.

The data of lamp replacement monitor timer is stored in the IC302. Please note that the lamp replacement monitor timer is reset when the memory IC (IC302) is replaced.

(Lamp replacement monitor time can not be set to the previous value.)

### Caution to memory IC replacement

When IC302 is replaced with new one, the CPU writes down the default data of the service adjustments to the replaced IC, refer to the service adjustment table. As these data are not the same data as factory shipped data, it should be required to perform the re-adjustments following to the “Electrical Adjustments”.

**CAUTION**

Please note that the lamp replacement monitor timer is reset.

### Caution of Main Board replacement (in the case IC302 is not defective)

When the main board is replaced, IC302 should be replaced with the one on previous main board. After replacement, it should be required to perform the re-adjustments following to the “Electrical Adjustments”.

In this case, the lamp replacement monitor timer can be kept the value as before.

## 1.1 Adjustments after Parts Replacement

● : Adjustment necessary ○ : Check necessary

		Disassembly / Replaced Parts								
		LCD/ Prism Ass'y	Integrator lens	Relay Lens	Polarized glass			Power Board	Component Board	Main Board
					R	G	B			
<b>Optical Adjustments</b>	Integrator Lens Adjustment	○	●							
	Relay Lens Adjustment	○		●						
	Contrast Adjustment									
	R-Contrast adjustment				●					
	G-Contrast adjustment					●				
	B-Contrast adjustment						●			
<b>Electrical Adjustments</b>	Output voltage adjustment						●			
	FAN voltage adjustment							●	●	
	PC offset adjustment								●	
	PC gain adjustment								●	
	Component gain adjustment								●	
	AV gain adjustment								●	
	PSIG Adjustment								●	
	Signal center adjustment								●	
	PC Gamma off video adjustment								●	
	PC/AV signal adjustment-1								●	
	PC/AV signal adjustment-2								●	
	S/H clock adjustment								●	
	Common center adjustment	●							●	
	White balance adjustment	○							○	
	Black balance adjustment	○							○	

## 1.2 Service Adjustment Menu Operation

### To enter the service mode

To enter to the “Service Mode”, press and hold the **MENU** and **NORMAL** button on the projector at the same time for more than 3 seconds. The service mode display appears on the screen as follows.

### To adjust service data

Select the adjustment item no. by pressing the pointer  $\odot$  or  $\ominus$  button, and change the data value by pressing the pointer  $\odot$  or  $\ominus$  button. Refer to the “Service Adjustment Data Table” for further description of adjustment item no. and data value.

### To return to the normal mode

To exit the service mode, press the **POWER** button on the projector or remote control unit.

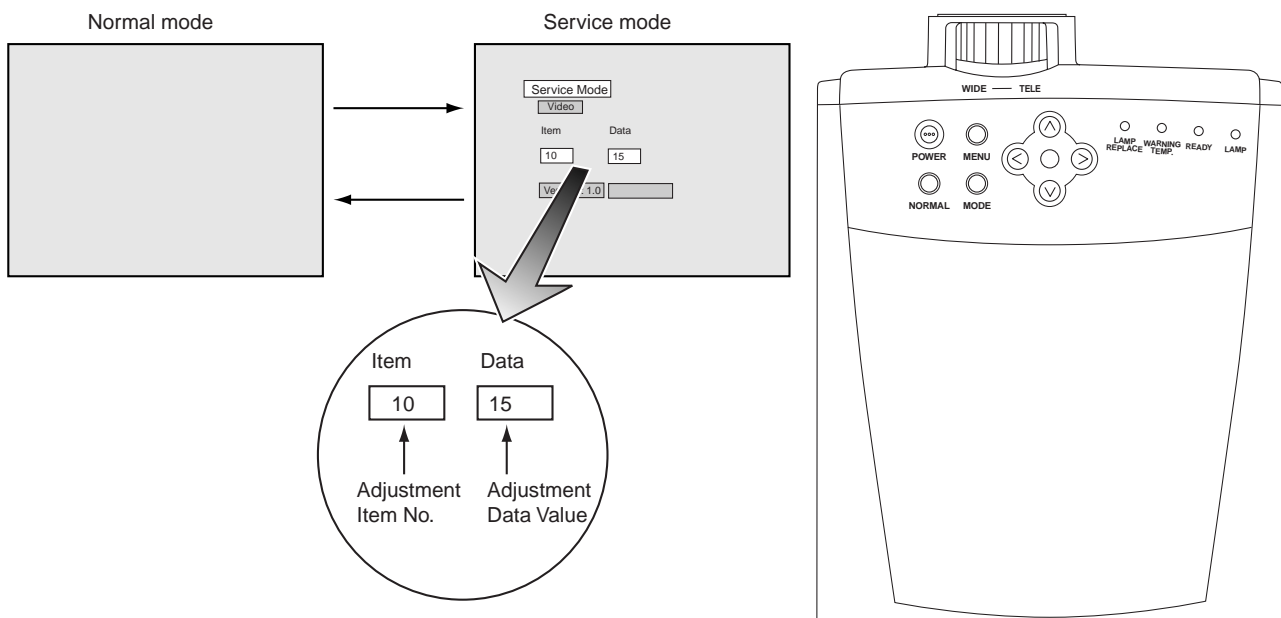

Fig. 3-1

### 1.3 Service Conditions

When you carry out the electrical, optical service adjustment or repairing with cabinet top removal, it should be done under the service conditions listed below. If you can not keep the one of following conditions, the projector turns off automatically by operating the protection circuit.

<b>Service Conditions:</b>
Operating Temperature : 41°F ~ 81°F (5°C ~ 30°C)
Fans Control : Maximum
AC Power Supply : 100 ~ 120V or 200V ~ 240V

To set the Fan Control to maximum, follow the Fan Control Setting Procedure below;

#### Fan Control Setting Procedure

1. Enter to the service mode.
2. Select adjustment item no.<29> and change data value to <0> to <1>. Now the cooling fans operate in maximum.
3. Exit from the service mode.

After finishing the works, restore the service data to <0> following to the steps 1 to 3.

\*Please refer to the “Service Adjustment Menu Operation” described on page 23 for how to entering the service mode and changing the service data.

### 1.4 Service Adjustment Data Table

These initial values are the reference data written from the CPU ROM to the memory IC when the new memory IC replaced. The adjustment items indicated with "\*" are required to readjust following to the "Electrical adjustments". Other items should be used with the initial data value.

No.	Adjustment Item	Initial Value			Range	Description
		PC	CV or S	Y/Cb/Cr		
0	RGB AMP (Gamma OFF) *	30	30		0 - 63	Same as No.1 of RGB AMP(Gamma ON)
1	RGB AMP (Gamma ON)	30	30			To up/down R/G/B of Gamma at same time system stop up/down, when R, G or B value reached Max or Min value.
2	S&H Test pattern display position		3		0 - 12	Test pattern display depend on setting value, test pattern move to right, 1 dot each by increasing data value.
3	GAMMA DLY CNT *		25		0 - 63	Display Green test pattern where Service No2 setting position.
4	GAMMA G BIAS		5		0 - 63	
5	Not used					
6	GAMMA R BIAS		5		0 - 63	
7	Not used					
8	GAMMA B BIAS		5		0 - 63	
9	GAMMA R-B1P *	27	28	28	0 - 63	White balance adjustment of Black portion in AV mode for Red
10	GAMMA B-B1P *	27	28	28	0 - 63	White balance adjustment of Black portion in AV mode for Blue
11	GAMMA G-B1P	27	28	28	0 - 63	White balance adjustment of Black portion in AV mode for Green
12	DAC CLAMP LEVEL(SUB BRIGHT) *	30	30		0 - 63	Sub-Bright(refer to DAC IC Control and User control spec)
13	GAMMA R GAIN *	30	30		0 - 63	
14	GAMMA B GAIN *	30	30		0 - 63	
15	DAC RGB BIAS *	50	50		0 - 125	G-Bias adjust value(refer to DAC IC Control and User control spec)
16	DAC R BIAS *	50	50	50	0 - 125	R-Bias adjust value(refer to DAC IC Control and User control spec)
17	DAC B BIAS *	50	50	50	0 - 125	B-Bias adjust value(refer to DAC IC Control and User control spec)
18	DAC RGB GAIN(SUB CONTRAST)	20	30		0 - 63	Sub-CONT(refer to DAC IC Control and User control spec)
19	S&H B-CK		12		0 - 255	Display Blue test pattern where Service No2 setting position.
20	S&H G-CK		12		0 - 255	Display Green test pattern where Service No2 setting position.
21	S&H R-CK		12		0 - 255	Display Red test pattern where Service No2 setting position.
22	Setting for Shoot out mode		0		0 - 2	0;Normal/ 1;Shoot out1/ 2;Shoot out2
23	Serial baud rate setting		1		0 - 2	0;9600/ 1;19200/ 2;38400
24	Lamp life time display		0			Read Only
25	S&H HCK PHASE adjust		4		0 - 15	Display Green test pattern where Service No2 setting position.
26	GAMMA R_WHP	57	57	57	0 - 63	
27	GAMMA G_WHP	57	57	57	0 - 63	
28	GAMMA B_WHP	57	57	57	0 - 63	
29	Fan Control *		0		0 or 1	Fans control for high land, control FAN_CONT1/FAN_CONT2. 0 : automatic, 1 : Forced High speed
30	D/A gain *	128	128	128	0 - 255	
			<b>NTSC</b>	<b>PAL</b>		
36	VD Analog Cont3(CV)		72		0 - 255	
37	VD Analog Cont4		0		0 - 255	
42	VD Bright	148	130		0 - 255	
43	VD Contrast	68	68		0 - 255	
64	VD Analog Cont3(S-Video)		72		0 - 255	
			<b>PC</b>	<b>Y/Cb/Cr</b>		
272	REDGAIN	96	96		0 - 255	
273	GRNGAIN *	96	96		0 - 255	
274	BLUGAIN *	96	96		0 - 255	
275	REDOFST *		32		0 - 63	
276	GRNOFST *		32		0 - 63	
277	BLUOFST *		32		0 - 63	
278	CLDUR	--	--		0 - 255	
279	CLPLACE	--	--		0 - 255	

## Part 3: Adjustment

No.	Adjustment Item	Initial Value	Range	Description
	For Fan Control			
283	Ter	2	0 - 31	
284	t	1	2 - 5	Temperature checking period, 0.5/1.0/1.5/2.0/2.5/3.0 sec.
285	TaH	52	0 - 255	
286	TaL	46	0 - 255	
287	TbH	44	0 - 255	
288	TbL	38	0 - 255	
289	Th	15	0 - 255	
290	Not used			
291	Sub Sharpness (YCbCr)	8	0 - 15	Refer to User control spec
292	Sub Tint (Video)	0	0 - 191	Refer to User control spec
293	Sub Color (Video)	26	0 - 63	
294	Sub Sharpness ( Video)	4	0 - 4	Select the PW Filter
295	Sub Color (YCbCr)	8	0 - 15	Refer to Use control spec.
296	Not used			
297	Expand Ratio (Vertical) 60Hz	3	--	Video and S-Video mode only.
298	Expand Ratio (Horizontal) 60Hz	11	--	
299	Position (Horizontal) 60Hz	402	--	
300	Position (Vertical) 60Hz	300	--	
301	Expand Ratio (Vertical) 50Hz	6	--	
302	Expand Ratio (Horizontal) 50Hz	12	--	
303	Position (Horizontal) 50Hz	403	--	
304	Position (Vertical) 50Hz	300	--	
305	Expand Ratio (Vertical) 480i	13	--	For Component mode and RGB NTSC
306	Expand Ratio (Horizontal) 480i	17	--	
307	Position (Horizontal) 480i	407	--	
308	Position (Vertical) 480i	308	--	
309	Expand Ratio (Vertical) 575i	21	--	For Component mode and RGB PAL
310	Expand Ratio (Horizontal) 575i	25	--	
311	Position (Horizontal) 575i	408	--	
312	Position (Vertical) 575i	313	--	
313	Expand Ratio (Vertical) 480p	9	--	For Component mode
314	Expand Ratio (Horizontal) 480p	10	--	
315	Position (Horizontal) 480p	409	--	
316	Position (Vertical) 480p	300	--	
317	Expand Ratio (Vertical) 575p	22	--	For Component mode
318	Expand Ratio (Horizontal) 575p	26	--	
319	Position (Horizontal) 575p	406	--	
320	Position (Vertical) 575p	308	--	
321	Expand Ratio (Vertical) 720p	12	--	For Component mode
322	Expand Ratio (Horizontal) 720p	20	--	
323	Position (Horizontal) 720p	406	--	
324	Position (Vertical) 720p	296	--	
325	Expand Ratio (Vertical) 1035i	13	--	For Component mode and RGB HDTV 1035i
326	Expand Ratio (Horizontal) 1035i	31	--	
327	Position (Horizontal) 1035i	403	--	
328	Position (Vertical) 1035i	303	--	
329	Expand Ratio (Vertical) 1080i	15	--	For Component mode and RGB HDTV 1080i
330	Expand Ratio (Horizontal) 1080i	31	--	
331	Position (Horizontal) 1080i	403	--	
332	Position (Vertical) 1080i	304	--	

## 2. ELECTRICAL ADJUSTMENTS

### CAUTION

The each circuit has been made by the fine adjustment at factory. Do not attempt to adjust the following adjustments except requiring the readjustments in servicing otherwise it may cause loss of performance and product safety.

### [Adjustment condition]

- Input signal
  - Video signal: 1.0Vp-p/75Ω terminated, 16 steps gray scale (Composite video signal)
  - Component Video signal: 0.7Vp-p/75Ω terminated, 16 steps gray scale (Component video signal with 480i, 480p, 575p, 720p, 1035i or 1080i format)
  - Computer signal: 0.7Vp-p/75Ω terminated, 16 steps gray scale pattern (SVGA)
- Picture control mode "NORMAL" mode unless otherwise noted.

### Note:

- \* Please refer to "Service Adjustment Menu Operation" for entering to the service mode and adjusting the service data.

### 2.1 Output Voltage Adjustment

After replacing the Power Board, P.F.C. Board, readjust the Output voltage adjustment as follows.

1. Connect a digital voltmeter to pins 1 (+) and 3 (-) of K6C.
2. Adjust the voltage by using VR01 as following.

AC Input	Reading
230V	380V ±2V
120V	372V ±2V

### CAUTION

Be sure to connect the lamp when taking this adjustment.

### 2.2 Fan Voltage Adjustment

1. Connect a digital voltmeter to test point "TP6602" (+) and chassis ground (-).
2. Enter to the service mode, select item no. "29" and set data value to "1".
3. Adjust the voltage to be 12.1 ±0.1Vdc by using VR6601.
4. Check that the voltages at test points "TP6601" (+), "TP6603" (+) and chassis ground (-) are 13.0 to 13.5Vdc.
5. Select item no. "29" and set data value to "0".

## 2.3 PC-Offset Adjustment

1. Receive the 16-step gray scale computer signal.
2. Set to **COMPUTER** mode.

### [R-Offset adjustment]

3. Connect an oscilloscope to test point "TP2212R" (+) and chassis ground (-).
4. Enter to the service mode, select item no. "275" and change data value to adjust the pedestal level and black level to be same level.

### [G-Offset adjustment]

5. Connect an oscilloscope to test point "TP2222G" (+) and chassis ground (-).
6. Select item no. "276" and change data value to adjust the pedestal level and black level to be same level.

### [B-Offset adjustment]

7. Connect an oscilloscope to test point "TP2232B" (+) and chassis ground (-).
8. Select item no. "277" and change data value to adjust the pedestal level and black level to be same level.

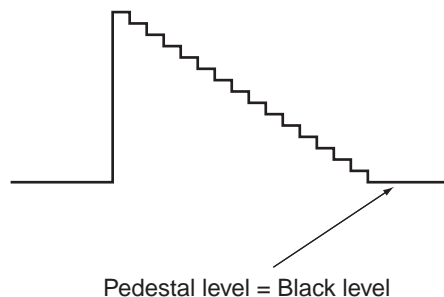

Fig. 3-2

## 2.4 PC Gain Adjustment

1. Receive the 16-step gray scale computer signal.
2. Set to **COMPUTER** mode.

### [PC-R gain adjustment]

3. Connect an oscilloscope to test point "TP2212R" (+) and chassis ground (-).
4. Enter to the service mode, select item no. "30" and change data value to adjust "a" to be  $1.13 \pm 0.01V_{p-p}$ .

### [PC-G gain adjustment]

5. Connect an oscilloscope to test point "TP2222G" (+) and chassis ground (-).
6. Select item no. "273" and change data value to adjust "a" to be  $1.13 \pm 0.01V_{p-p}$ .

### [PC-B gain adjustment]

7. Connect an oscilloscope to test point "TP2232B" (+) and chassis ground (-).
8. Select item no. "274" and change data value to adjust "a" to be  $1.13 \pm 0.01V_{p-p}$ .



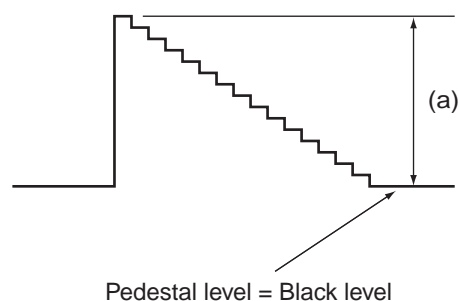

Fig. 3-3

## 2.5 Component Gain Adjustment

1. Receive the 16-step gray scale component video signal.
2. Set to **VIDEO** (Component) mode.

### [Component-R gain adjustment]

3. Connect an oscilloscope to test point "TP2212R" (+) and chassis ground (-).
4. Enter to the service mode, select item no. "30" and change data value to adjust "a" to be  $1.05 \pm 0.01V_{p-p}$ .

### [Component-G gain adjustment]

5. Connect an oscilloscope to test point "TP2222G" (+) and chassis ground (-).
6. Select item no. "273" and change data value to adjust "a" to be  $1.05 \pm 0.01V_{p-p}$ .

### [Component-B gain adjustment]

7. Connect an oscilloscope to test point "TP2232B" (+) and chassis ground (-).
8. Select item no. "274" and change data value to adjust "a" to be  $1.05 \pm 0.01V_{p-p}$ .

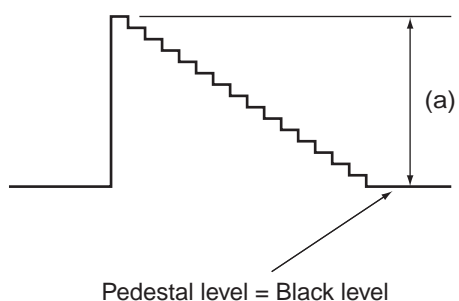

Fig. 3-4

## 2.6 AV Gain Adjustment

1. Receive the 16-step gray scale video signal.
2. Set to **VIDEO** mode.
3. Connect an oscilloscope to test point "TP2222G" (+) and chassis ground (-).
4. Enter to the service mode, select item no. "30" and change data value to adjust "a" to be  $1.05 \pm 0.01\text{Vp-p}$ .

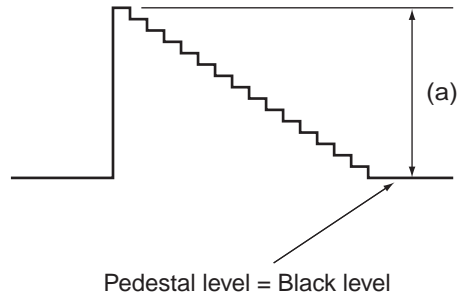

Fig. 3-5

## 2.7 NRS Adjustment

1. Receive the 16-step gray scale computer signal.
2. Set to **COMPUTER** mode.
3. Connect an oscilloscope to test point "TP3581" (+) and chassis ground (-).
4. Adjust "a" to be  $5.0 \pm 0.1\text{V}$  by using VR3561.

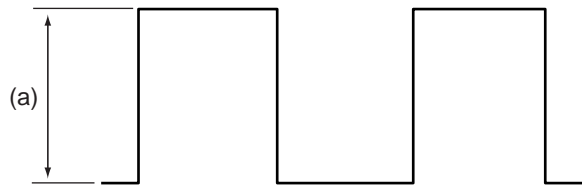

Fig. 3-6

## 2.8 Signal Center Adjustment

1. Receive the 16-step gray scale computer signal.
2. Set to **COMPUTER** mode.

### [R-signal center adjustment]

3. Connect a digital voltmeter to test point "TP511" (+) and chassis ground (-).
4. Adjust voltage to be  $7.30 \pm 0.05V$  by using VR521.

### [G-signal center adjustment]

5. Connect a digital voltmeter to test point "TP512" (+) and chassis ground (-).
6. Adjust voltage to be  $7.30 \pm 0.05V$  by using VR551.

### [B-signal center adjustment]

7. Connect a digital voltmeter to test point "TP513" (+) and chassis ground (-).
8. Adjust voltage to be  $7.30 \pm 0.05V$  by using VR581.

## 2.9 PC/AV Gamma Off Adjustment

### [PC-gamma off adjustment]

1. Receive the 16-step gray scale computer signal.
2. Set to **COMPUTER** mode.
3. Connect an oscilloscope to test point "TP512" (+) and chassis ground (-).
4. Enter to the service mode, select item no. "0" and change data value to adjust "a" to be  $1.60 \pm 0.01V_{p-p}$ .

### [AV-gamma off adjustment]

5. Receive the 16-step gray scale video signal.
6. Set to **VIDEO** mode.
7. Connect an oscilloscope to test point "TP512" (+) and chassis ground (-).
8. Select item no. "0" and change data value to adjust "a" to be  $1.70 \pm 0.01V_{p-p}$ .

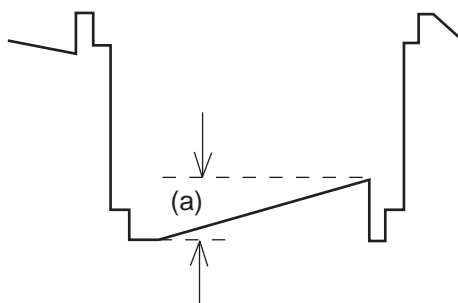

Fig. 3-7

### Note:

- \* This adjustment should be carried out before adjusting PC/AV-Video Adjustment-1 and 2.

## 2.10 PC/AV-Video Adjustment-1

### Presetting

1. Input the 16-step gray scale video signal and computer signal.

### [PC/AV-video adjustment]

2. Connect an oscilloscope to test point "TP512" (+) and chassis ground (-).
3. Enter to the service mode, select item no. "15" and change data value to adjust "b" to be  $1.8 \pm 0.01V_{p-p}$  at each **VIDEO** and **COMPUTER** mode.
4. Set to **COMPUTER** mode, select item no. "12" and change data value to adjust "a" to be  $4.00 \pm 0.01V_{p-p}$ .
5. Set to **VIDEO** mode, select item no. "12" and change data value to adjust "a" to be  $4.00 \pm 0.01V_{p-p}$ .

### [R-video adjustment]

6. Connect an oscilloscope to test point "TP511" (+) and chassis ground (-).
7. Set to **COMPUTER** mode, select item no. "13" and change data value to adjust "a" to be  $4.00 \pm 0.01V_{p-p}$ .
8. Set to **VIDEO** mode and item no. "13" and change data value to adjust "a" to be  $4.00 \pm 0.01V_{p-p}$ .

### [B-video adjustment]

9. Connect an oscilloscope to test point "TP513" (+) and chassis ground (-).
10. Set to **COMPUTER** mode, select item no. "14" and change data value to adjust "a" to be  $4.00 \pm 0.01V_{p-p}$ .
11. Set to **VIDEO** mode and item no. "14" and change data value to adjust "a" to be  $4.00 \pm 0.01V_{p-p}$ .

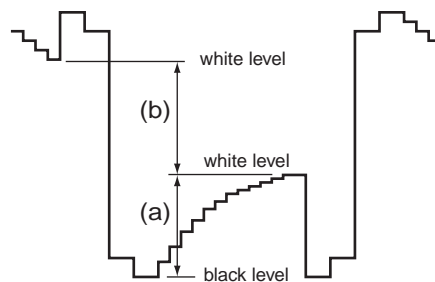

Fig. 3-8

## 2.11 PC/AV-Video Adjustment-2

### [PC-video adjustment-2]

1. Receive the 16-step gray scale computer signal.
2. Set to **COMPUTER** mode.
3. Connect an oscilloscope to test point "TP512" (+) and chassis ground (-).
4. Enter to the service mode, select item no. "15" and change data value to adjust "b" to be  $1.90 \pm 0.01\text{Vp-p}$ .

### [AV-video adjustment-2]

5. Receive the 16-step gray scale video signal.
6. Set to **VIDEO** mode.
7. Connect an oscilloscope to test point "TP512" (+) and chassis ground (-).
8. Select item no. "15" and change data value to adjust "b" to be  $2.00 \pm 0.01\text{Vp-p}$ .

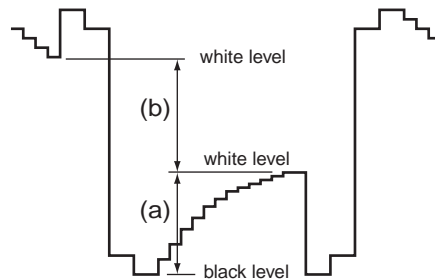

Fig. 3-9

## 2.12 S/H Clock Adjustment

1. Receive the 16-step gray scale computer signal.
2. Set to **COMPUTER** mode.
3. Connect an oscilloscope to test point "TP512" (+) and chassis ground (-).
4. Enter to the service mode, select item no. "3" and change data value to adjust "a" to be maximum.

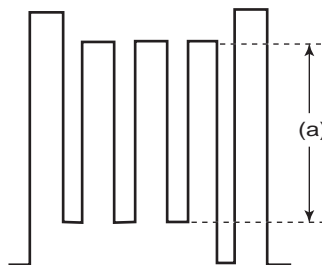

Fig. 3-10

## 2.13 Common Center Adjustment

1. Receive the 1 dot line computer signal.
2. Set to **COMPUTER** mode.

### [R-common center adjustment]

3. Cover the G and B panel to block the light transit.
4. Adjust VR2561 to obtain the minimum flicker on the picture.

### [G-common center adjustment]

5. Cover the R and B panel to block the light transit.
6. Adjust VR2571 to obtain the minimum flicker on the picture.

### [B-common center adjustment]

7. Cover the G and R panel to block the light transit.
8. Adjust VR2581 to obtain the minimum flicker on the picture.

## 2.14 White Balance Adjustment

### [PC white balance adjustment]

1. Receive the 16-step gray scale computer signal.
2. Set to **COMPUTER** mode.
3. Enter to the service mode, select item no. "16" (Red) or "17" (Blue), and change data values respectively to make a proper white balance.

### [AV white balance adjustment]

4. Receive the 16-step gray scale video signal.
5. Set to **VIDEO** mode.
6. Select item no. "16" (Red) or "17" (Blue), and change data values respectively to make a proper white balance.

### [Component white balance adjustment]

7. Receive the 16-step gray scale component video signal.
8. Set to **VIDEO** (Component) mode.
9. Select item no. "16" (Red) or "17" (Blue), and change data values respectively to make a proper white balance.

Confirm that the same white balance is obtained in video, computer and component input.

## 2.15 Black Balance Adjustment

### [PC black balance adjustment]

1. Receive the 16-step gray scale computer signal.
2. Set to **COMPUTER** mode.
3. Enter to the service mode, select item no. "9" (Red) or "10" (Blue), and change data values respectively to make a proper white balance at darker portion of the screen.

### [AV black balance adjustment]

4. Receive the 16-step gray scale video signal.
5. Set to **VIDEO** mode.
6. Select item no. "9" (Red) or "10" (Blue), and change data values respectively to make a proper white balance at darker portion of the screen.

### [AV black balance adjustment]

7. Receive the 16-step gray scale component video signal.
8. Set to **VIDEO** (Component) mode.
9. Select item no. "9" (Red) or "10" (Blue), and change data values respectively to make a proper white balance at darker portion of the screen.

Confirm that the same white balance is obtained at darker portion of the screen in video, computer and component input.

## 2.16 Note on White Uniformity Adjustment

If you find the color shading, please adjust the white uniformity by using the proper computer and "Color Shading Correction" software.

<b>COLOR SHADING CORRECTION</b> (Ver. 2.0.2)
--

Attached with this manual
---------------------------

## 3. OPTICAL ADJUSTMENTS

### 3.1 Contrast Adjustment

#### [Before adjustment]

- Adjustment requires a 2.0mm hex wrench and a slot screwdriver.
- Remove cabinet top following to “Mechanical Disassemblies”.
- Input a 100% of black raster signal.

**CAUTION**

Do not disconnect the connectors on main and component boards otherwise the projector can not be turned on.

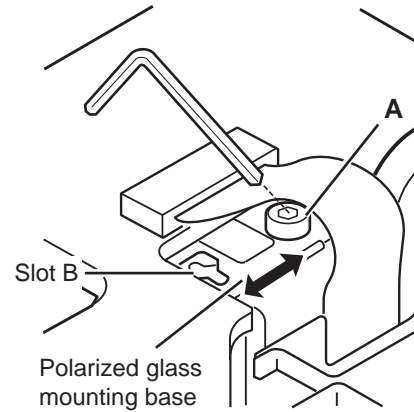

Fig. 3-11

#### [R/G/B-contrast adjustment]

1. Shield the unnecessary lights by inserting the thick paper etc. in front of the LCD panels .  
When adjusting the R-Contrast, project red light only.  
When adjusting the G-Contrast, project green light only.  
When adjusting the B-Contrast, project blue light only.
2. Loosen a screw **A** (Fig.3-11/3-12) on the polarized glass mounting base which you intend to adjust.
3. Adjust a slots **B** as shown in Fig.3-11 to obtain the darkest brightness on the screen by turning a slot screwdriver.
4. Tighten the screw **A** to fix the polarized glass mounting base.  
Repeat steps 1 to 4 for remaining polarized glasses.

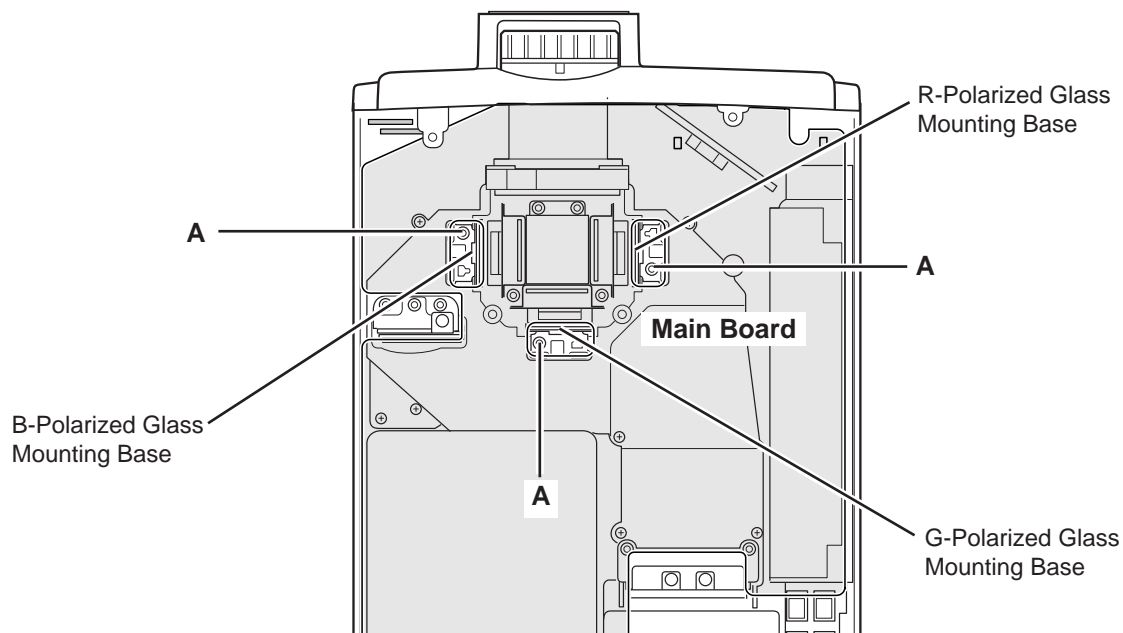

Fig. 3-12



## 3.2 Integrator Lens Adujstment

### [Before adjustment]

- Adjustment requires a 2.0mm hex driver and a slot screwdriver.
- Remove cabinet top following to “Mechanical Disassemblies”.

**CAUTION**

Do not disconnect the connectors on main and component boards otherwise the projector can not be turned on.

### [Adjustment]]

1. Turn on lamp by a state of without FPC cable of LCD panels.
2. Shield the red and blue lights by inserting thick papers etc. in front of Red and Blue LCD panels to project only green light and make a fine focus.
3. Remove the shield in front of Red LCD panel to project green and blue light.
4. Adjust the adjustment base of integrator lens ass'y to make color uniformity in yellow.
  - 1) If the color shade appears on the left or right of the screen as shown in Fig.3-13, loosen 1 screw **A** with the 2.0mm hex driver and adjust a slot **B** to make color uniformity in yellow by turning a slot screwdriver.
  - 2) If the color shade appears on the top or bottom of the screen as shown in Fig.3-14, loosen 2 screws **C** with the 2.0mm hex driver and adjust a slots **D** to make color uniformity in yellow by turning a slot screwdriver.
5. Tighten 1 screw **A** and 2 screws **C** to fix the integrator lens unit.
6. Remove the shield in front of Blue LCD panel and project red, green and blue light. Check that there is no color shade on the left or right of the screen. If you recognise the color shade, the “Relay Lens Adjustment” should be carried out to obtain the proper color uniformity.

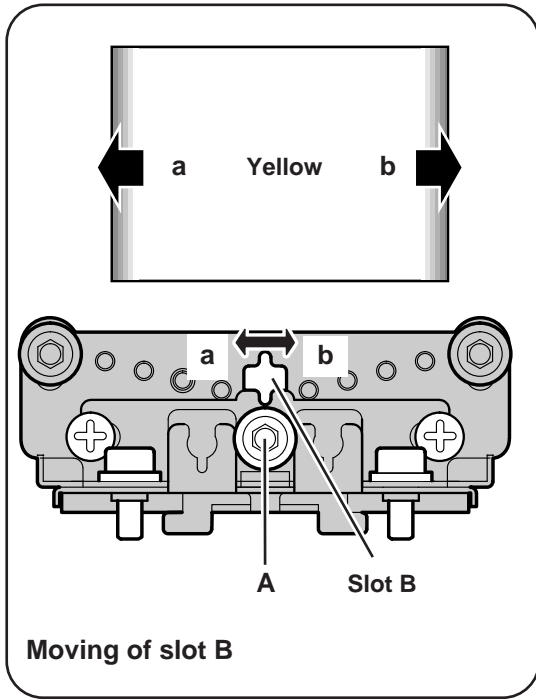

Fig. 3-13

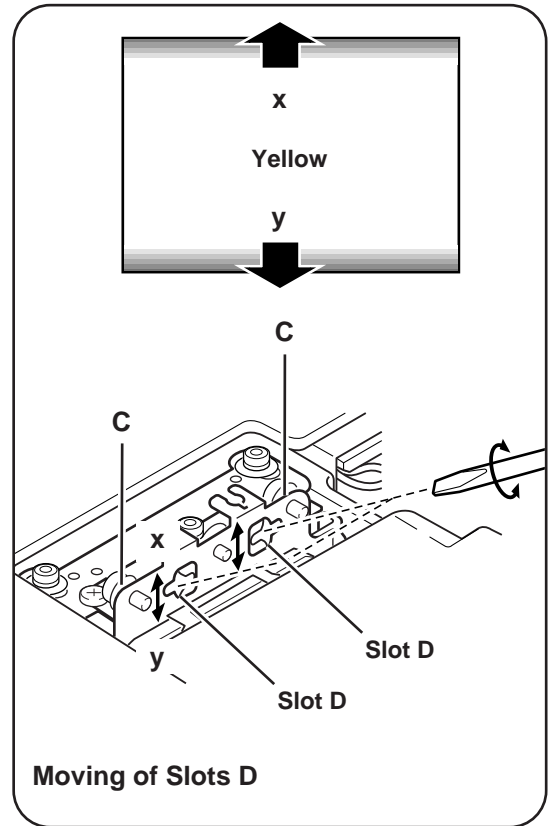
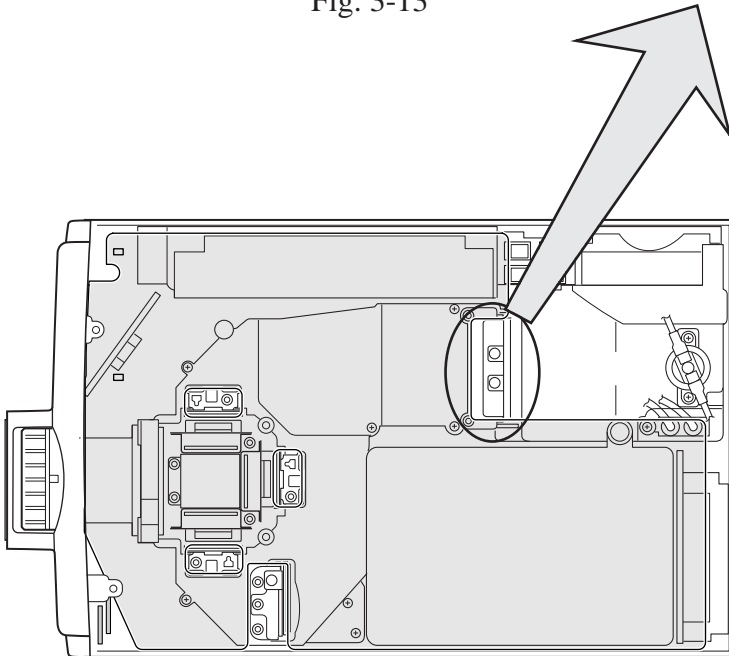

Fig. 3-14



### 3.3 Relay Lens Adjustment

#### [Before adjustment]

- Adjustment requires a 2.0mm hex driver and a slot screwdriver.
- Remove cabinet top following to “Mechanical Disassemblies”.

#### CAUTION

Do not disconnect the connectors on main and component boards otherwise the projector can not be turned on.

#### [Adjustment]

1. Turn on lamp by a state of without FPC cable of LCD panels.
2. Adjust the adjustment base of relay lens ass'y to make color uniformity in white. If the color shade appears on the left or right of the screen as shown in Fig.3-15, loosen a screw **A** with the 2.0mm hex driver and adjust the slot **B** to make color uniformity in white by using a slot screwdriver.
3. Tighten the 1 screw **A** to fix the relay lens unit.

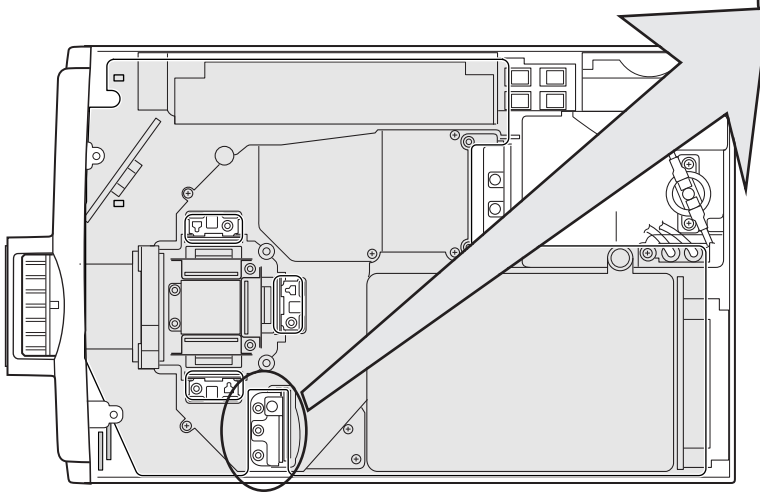
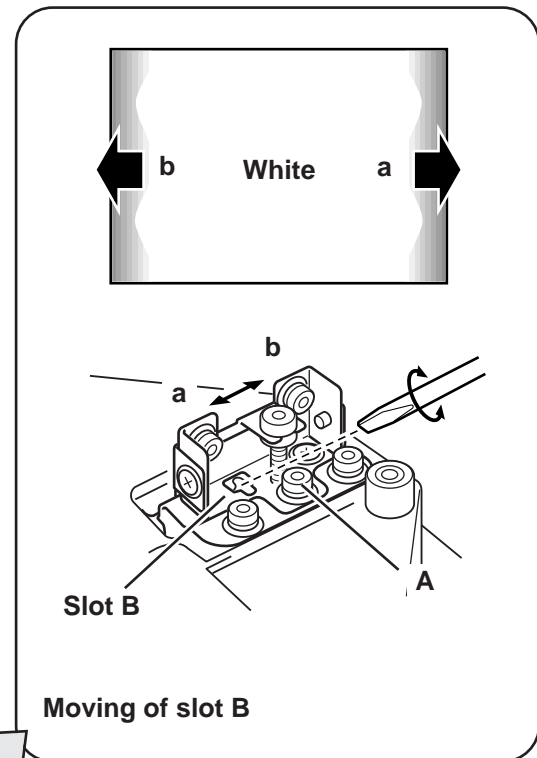
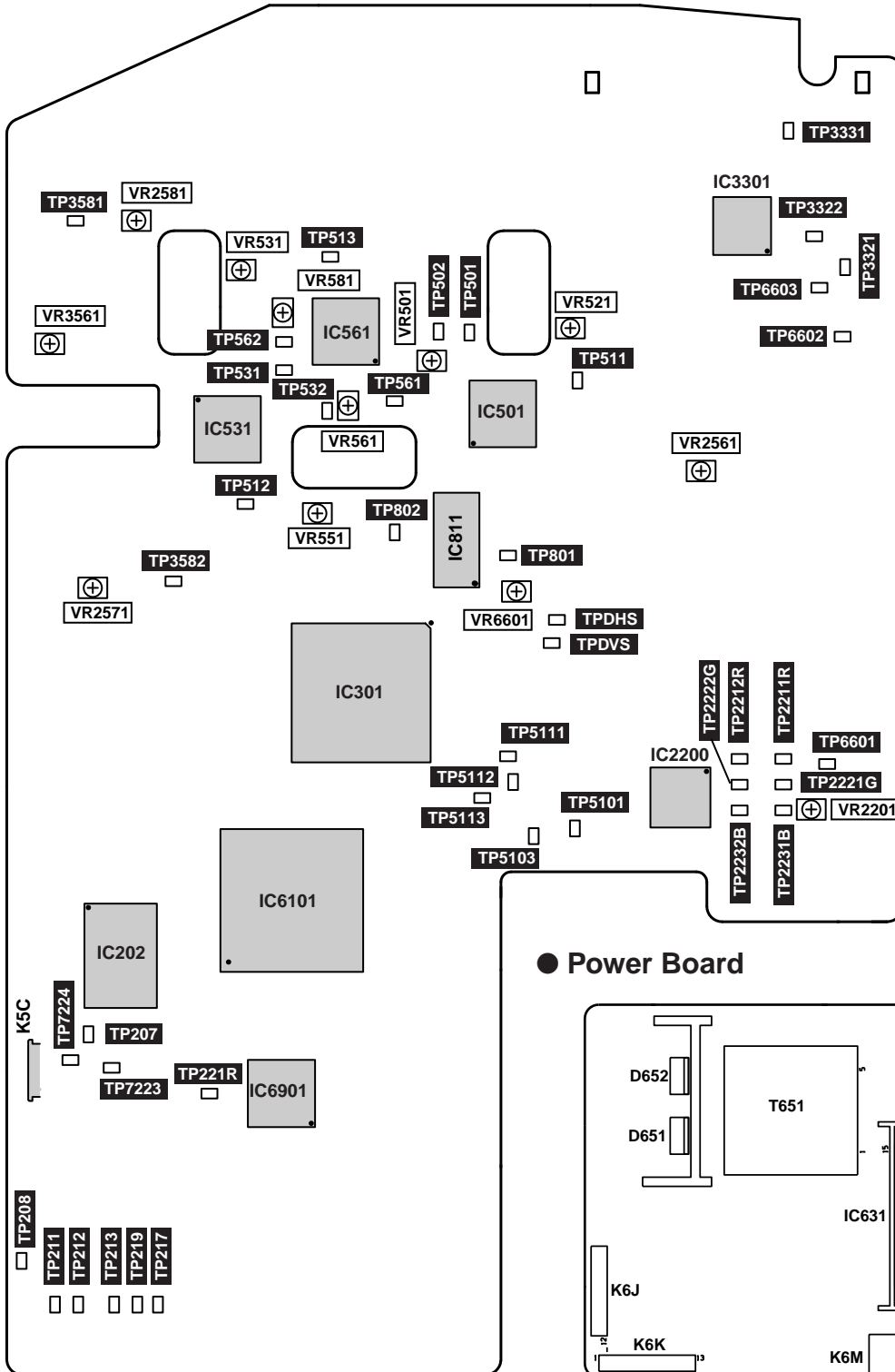

Fig. 3-15

## 4. TEST POINTS AND LOCATIONS

### ● Main Board



### ● Power Board

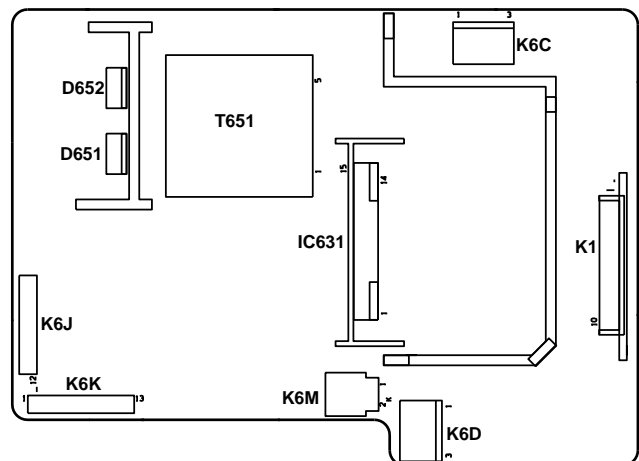

Fig. 3-16  
3-20

*Part 4*

---

*Troubleshooting*



# 1. TROUBLESHOOTING

## 1.1 No Power

### 1) Periphery of chassis

1. Is fuse (F901) blown?  
Fuse may be opened when either the LAMP indicator or the READY indicator isn't illuminated. Check the fuse.
  - For continued safety, replace with a fuse of the same type.  
TYPE T4.0AH 250V FUSE. (LITTLE FUSE INC. TYPE 215004)
2. Is projection of lamp cover inside broken or not fitting?  
Check the INTER LOCK switch(SW904) and lamp cover.  
SW904 .....OPEN : abnormal
3. Is thermal switch(SW902) operating?  
If temperatures periphery of lamp house reaches 100°C, the thermal switch will be turned off automatically.  
SW902 .....OPEN : abnormal
4. Is the WARNING TEMP. indicator flashing ? The thermal sensor IC (IC2832) on the Temp. board or IC2831 on the main board may detect the abnormal temperature inside of the projector. If one of these ICs detects the abnormal temperature, this projector will be turned off automatically.

### 2) Power board

1. Are the LAMP indicator(red) and READY indicator(green) light?  
If the LAMP and READY indicators do not illuminated, check the primary circuit and S6V of standby power supply circuit.
2. Check that the LAMP BST-SW signal is correct.  
Pin 12 of K6K .....H : ON
3. Check that the 5V\_SW signal is correct.  
Pin 11 of K6K .....H : ON
4. Check that the POWER FAIL signal is correct.  
Pin 13 of K6K .....L : abnormal
5. Is thermal switch(TSW611) operating?  
If temperatures periphery of P.F.C. circuit reaches 95°C, the thermal switch will be turned on automatically.  
TSW611 .....SHORT : abnormal
6. Check the signal at pin 5 of T651. (Switching power IC output signal)

### 3) Main board

1. Check that the 15.5V is observed at pins 1-3 of K3C.
2. Check that the 6V is observed at pins 6-8 of K3C.
3. Check that the -5V is observed at pin 9 of K3C.
4. Check that the 5V is observed at pins 10-11 of K3C.
5. Check that the 6V is observed at pins 2-4 of K3D.
6. Check that the 15.5V is observed at pins 7-8 of K3D.
7. Check that the 5V\_SW signal is correct.  
Pin 11 of K3D.....H : ON
8. Check that the LAMP BST\_SW signal is correct.  
Pin 12 of K3D.....H : ON
9. Check that the POWER FAIL signal is correct.  
Pin 13 of K3D.....L : abnormal
10. Check that the 12V is observed at test points TP6101. TP6102 and TP6103.
11. Check that the LAMP\_SW signal is correct.  
Pin 4 of K8CC.....H : On
12. Check that the LAMP\_ERR signal is correct.  
Pin 1 of K8CC.....L : On
13. Check that the POWER FAIL signal is correct.  
Pin 2 of IC1851 .....L : abnormal
14. Check that the Sensor IC(IC2831) detects abnormal temperature inside the projector.

### 4) Component board

1. Check Power Supply and switching circuit  
Check ICs IC2641 to IC2691
2. Check that the POWER FAIL signal is correct.  
Pin 11-12 of K3A .....L : abnormal
3. Check that the FAN\_DRIVE signal is correct.  
Pin 7-8 of K3A.....H : On



<Memo>

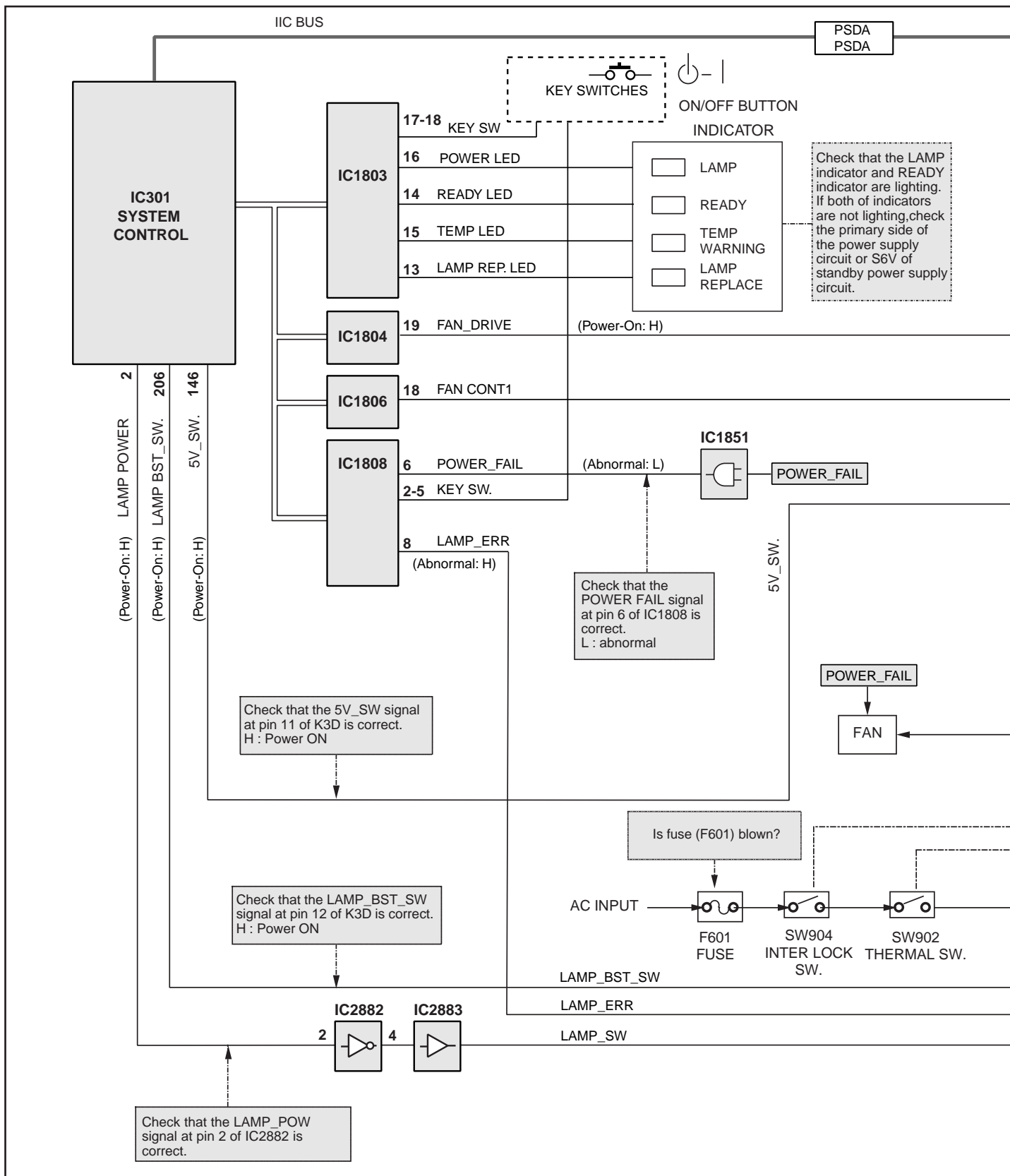
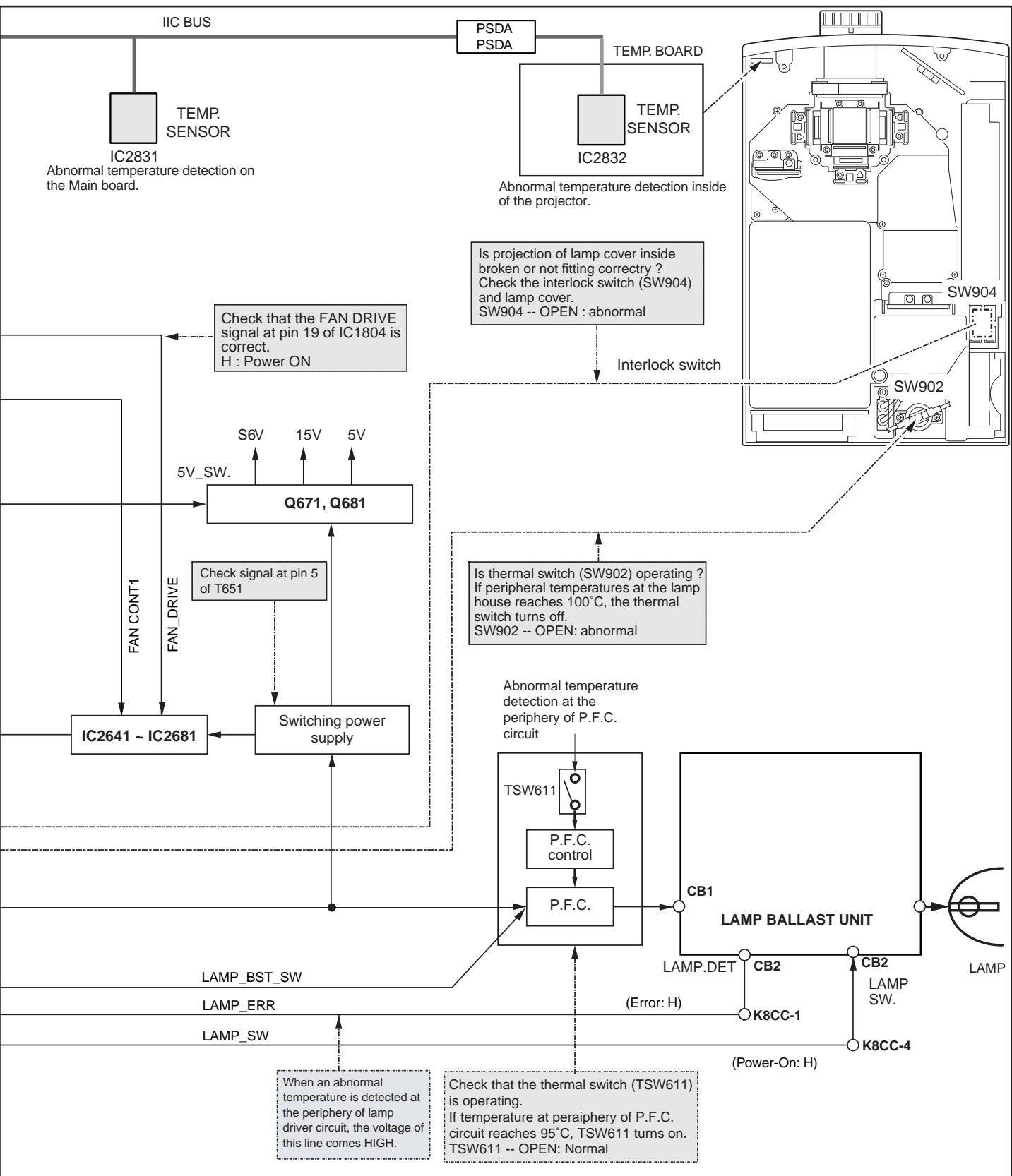

Fig. 4-1



## 1.2 No Sound

### 1) Main board

1. Check that the PC/AV switching signal is correct.  
Pins 10 and 11 of IC5001 .....AV : L, PC : H
2. Check that audio signal is observed at following points.  
Pins 11-12(PC)/13-14(AV) of K10B/K50B
3. Check that the MUTE signal is correct.  
Pin 5 of K5A .....Mute-On: H
4. Check that the MUTE signal is correct.  
Pin 12 of IC1803 .....Mute-On: L
5. Check that the PC/AV switching signal is correct.  
Pin 16 of IC1804 .....AV : L, PC : H

### 2) Audio board

1. Check that sound volume control signal is correct.  
Pin 4 of IC001
2. Check that audio signal is observed at pin 2 of IC001.
3. Check the MUTE signal at pin 3 of IC001.  
Pin 3 of IC001 .....Mute-On: H
4. Check that Vcc-voltage(+12V) is applied at pins 1 and 9 of IC001.

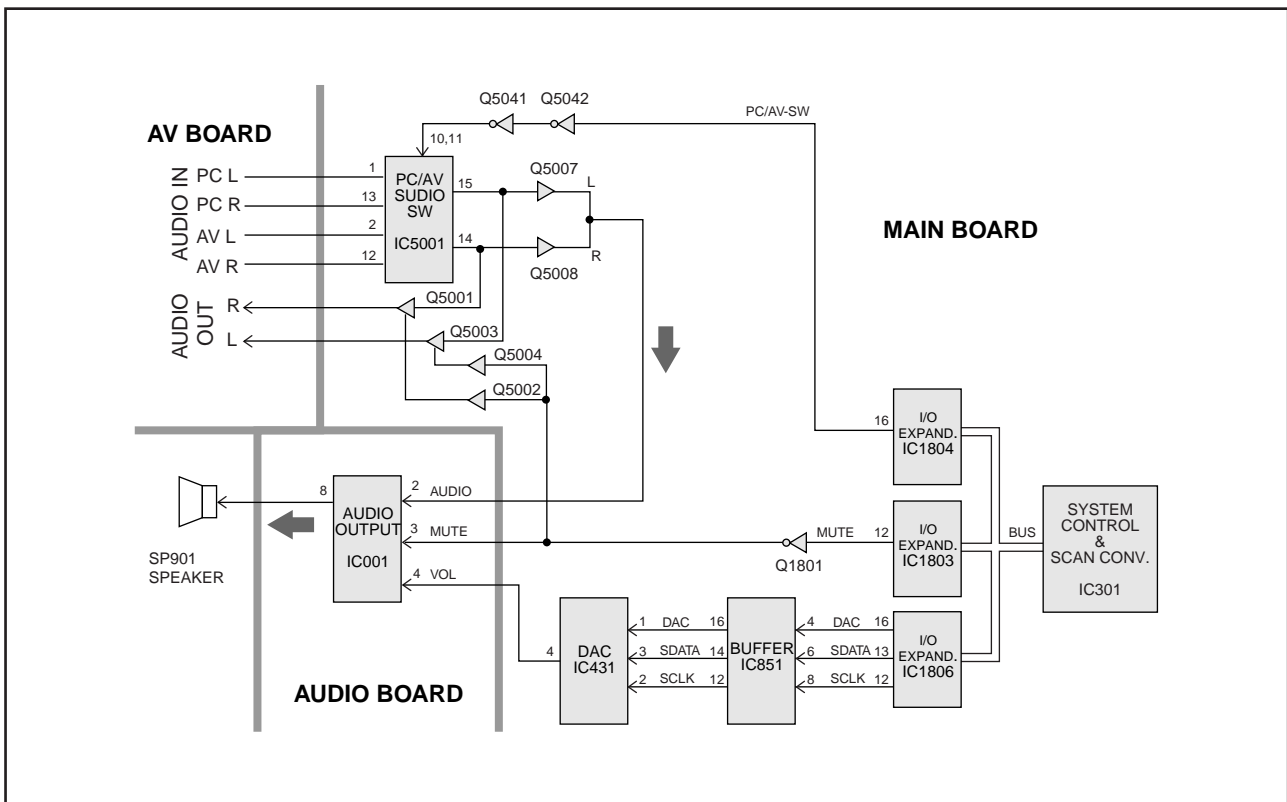

Fig. 4-2

## 1.3 No Picture

### 1) AV board

- Check that the Vcc-voltages(+5V, -5V) are applied to AV circuits.  
Pins 47-50 of K10A, Pins 47-54 of K10B .....5V  
Pins 39-42 of K10B .....-5V  
Check IC1001, IC1002 and IC1021.
- Check that the following input signals are observed correctly.

SIGNAL	K10A-pin No.	K50A-pin No.
V-Sync	17-18	17-18
H-Sync	15-16	15-16
B	11-12	11-12
G	9-10	9-10
R	7-8	7-8
Video	33-34	33-34
S-C	29-30	29-30
S-Y	25-26	25-26

### 2) Main board

- Check the signals at following test points.
  - Video signal at TP208, TP218
  - V-sync signal at TP7224
  - H-sync signal at TP7223
- Check that the PC/AV switching signal is correct.  
Pin 16 of IC5201 .....AV: H, PC: L  
Pin 5 of IC5282 .....AV: H, PC: L
- Check that the RGB signals are observed at following test points.  
TP211, TP221R, TP2211R .....R-signal  
TP212, TP221G, TP2221G .....G-signal  
TP213, TP221B, TP2231B .....B-signal
- Check that the signals are observed at following test points.  
TPDHS, TP3322 .....V-Sync,  
TPDVS, TP3321 .....H-Sync
- Check that the S/H signals are observed at following test points.  
TP501, TP511 .....R-signal  
TP531, TP512 .....G-signal  
TP561, TP513 .....B-signal
- Check that the NRS signals are observed at test points TP3581 and TP3582.

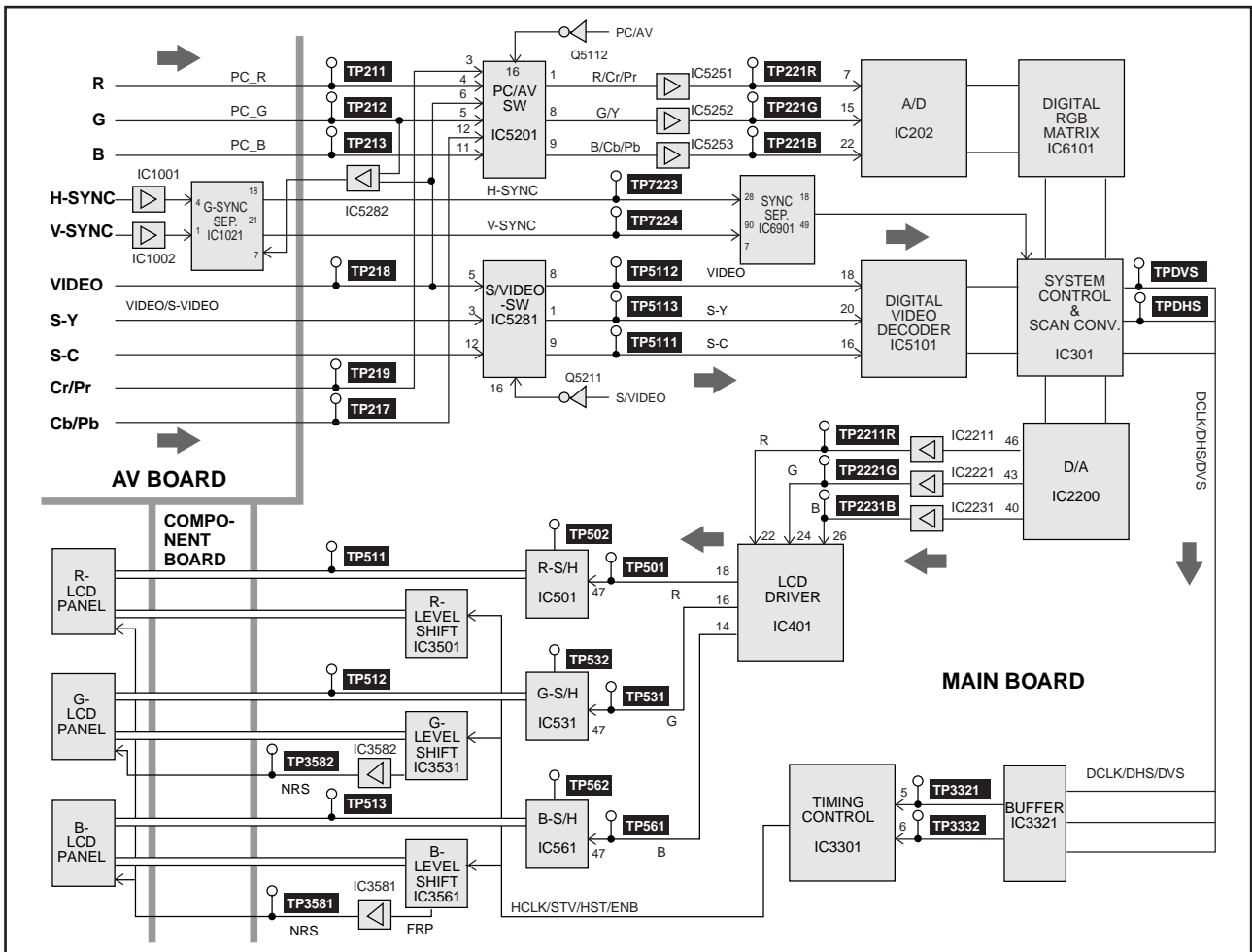

Fig. 4-3

## 2. CONTROL PORT FUNCTIONS

### 2.1 System Control & I/O Port Functions

IC Ref. No	Pin/Name	I/O	Signal Name	Function	Note
IC301	PortA0	I/O	ROMWEL	For ICE	
	PortA1	I/O	ROMWEH	For ICE	
	PortA2	I/O	BOOTWE	For ICE	
	PortA3	I/O	Not used	Fixed High	
	PortA4	O	5V_SW	Power ON/OFF	MainPower-ON: High
	PortA5	O	LAMP_BST_SW	Lamp Ballast ON/OFF	Lamp Ballast-ON: High
	PortA6	O	IO_Reset	Initialize I/O	I/O Active: Low
	PortA7	O	LAMP_POW	Lamp-ON	Lamp-ON: High
	PortB0	I/O	3L_EN	3-Line Serial ON/OFF	Serial Line-ON: Low
	PortB1	I/O	PortB1	MatrixSDA	
	PortB2	I/O	Mouse1	Mouse Control	Air Mouse-ON: High
	PortB3	I/O	Not used	Fixed High	
	PortB4	I/O	SCL_IN	Fixed High	
	PortB5	I/O	Not used	Fixed High	
	PortB6	I/O	M_SCL	IIC CLK	
	PortB7	I/O	M_SDA	IIC DATA	
	IC1803	12	O	Mute	Mute
13		O	LAMP_REP_LED	Lamp Replace LED Drive	ON: High
14		O	READY_LED	Ready LED Drive	ON: High
15		O	TEMP_LED	Temp Warning LED Drive	ON: High
16		O	POW_LED	Power LED Drive	ON: High
17		O	KO3	Main Key Switch	
18		O	KO2	Main Key Switch	
IC1804	19	O	KO1	Main Key Switch	
	12	O	CG_Filter	CG Filter ON/OFF	ON: High
	13	O	VHDREN	Philips chip Enable	ON: High
	14	O	VFIELD_SW	VField PC/AV Selection	Video V Field: High
	15	O	Y/G_SW	Sync Sep. Y/G Selection	Y: High G: Low
	16	O	PC/AV_SW	PC/AV Selection	PC: High AV: Low
	17	O	C/V_SW	Video/Component Selection	Video: Low Component: High
	18	O	PeriPow_SW	Power consumption SW in ST	Normal: High Standby: Low
	19	O	FanDrive_SW	Fan Drive ON/OFF	Fan Drive ON: High OFF: Low

IC Ref. No	Pin/Name	I/O	Signal Name	Function	Note
IC1806	12	O	SCLK	3-Line Serial Clock	
	13	O	SDATA	3-Line Serial Data	
	14	O	DAC_STLOBE	DAC	Data Effective: Low
	15	O	S&H_STLOBE	S&H	Data Effective: High
	16	O	IRM_STLOBE	White Uniformity	Data Effective: Low
	17	O	FAN_CONT2	Digital Pot. Chip Enable	Data Effective: Low
	18	O	FAN_CONT1	Fan Voltage Enable	Fan Control ON: High
	19	O	Not used		
	IC1807	12	O	Not used	
13		O	DVS2	Vsync x 2Hz Output	
14		O	LAMP_ON	Output Clock ON/OFF	Output Clock ON: High
15		O	LIM-OFF		
16		O	PWDN	For AD9884 Power Down	AD Power Down: High
17		O	NYSE		
18		O	CTS33	RS232C Relation	
IC1808	19	O	Not used		
	2	I	KI1	Main Key Switch	
	3	I	KI2	Main Key Switch	
	4	I	KI3	Main Key Switch	
	5	I	KI4	Main Key Switch	
	6	I	Power_fail	Power Fail Detection	Abnormal: Low Normal: High
	7	I	Not used		
	8	I	Lamp_ERR	Lamp Fail	Abnormal: Low Normal: High
	9	I	Not used		
IC1809	2	I	S_IN		
	3	I	CB_SW	Component	
	4	I	CR_SW	Component	
	5	I	CTS/V		
	6	I		OEM Option	
	7	I		OEM Option	
	8	I		OEM Option	
	9	I		SVGA/Video grade SW	SVGA: Low Video Grade: High



### 3. WAVEFORMS

<p>TP218 TP208 AV VIDEO</p>		<p>TP207 TP7223 AV H-SYNC</p>	
<p>TP7224 AV V-SYNC</p>		<p>TPDHS TP3322 DHS</p>	
<p>TPDVS TP3321 DVS</p>		<p>TP3581 NRS for R/B</p>	
<p>TP3582 NRS for G</p>		<p>TP2211R TP2212R D/A R-OUTPUT</p>	

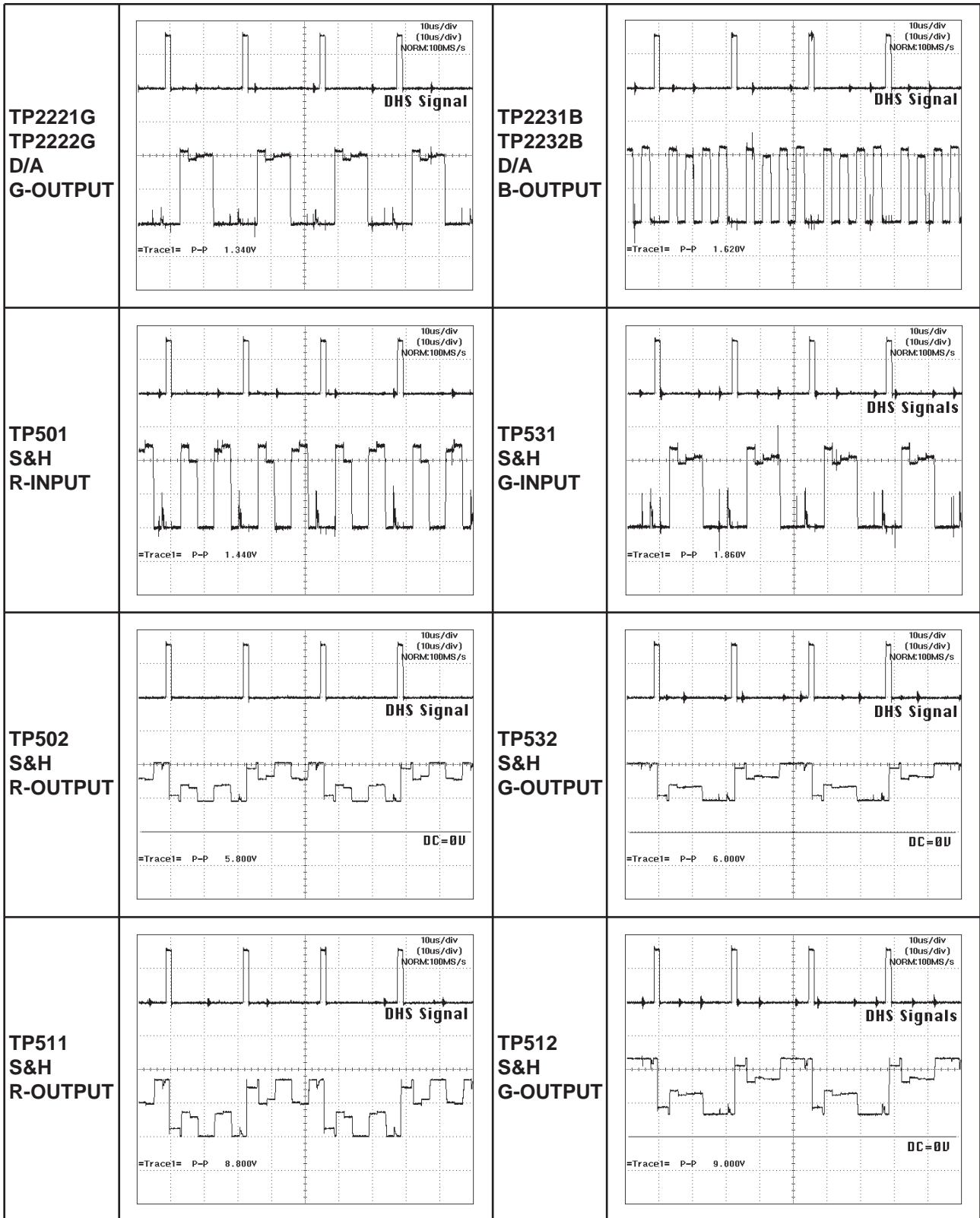

<p><b>TP561 S&amp;H B-INPUT</b></p>	<p>10us/div (10us/div) NORM:100MS/s</p> <p><b>DHS Signal</b></p> <p>=Trace1= P-P 1.400V</p>		
<p><b>TP562 S&amp;H B-OUTPUT</b></p>	<p>10us/div (10us/div) NORM:100MS/s</p> <p><b>DHS Signal</b></p> <p>=Trace1= P-P 5.800V</p> <p>DC=0V</p>		
<p><b>TP513 S&amp;H B-OUTPUT</b></p>	<p>10us/div (10us/div) NORM:100MS/s</p> <p><b>DHS Signal</b></p> <p>=Trace1= P-P 8.400V</p>		

## 4. IC BLOCK DIAGRAMS

### ● AN5265 <AUDIO OUTPUT, IC001>

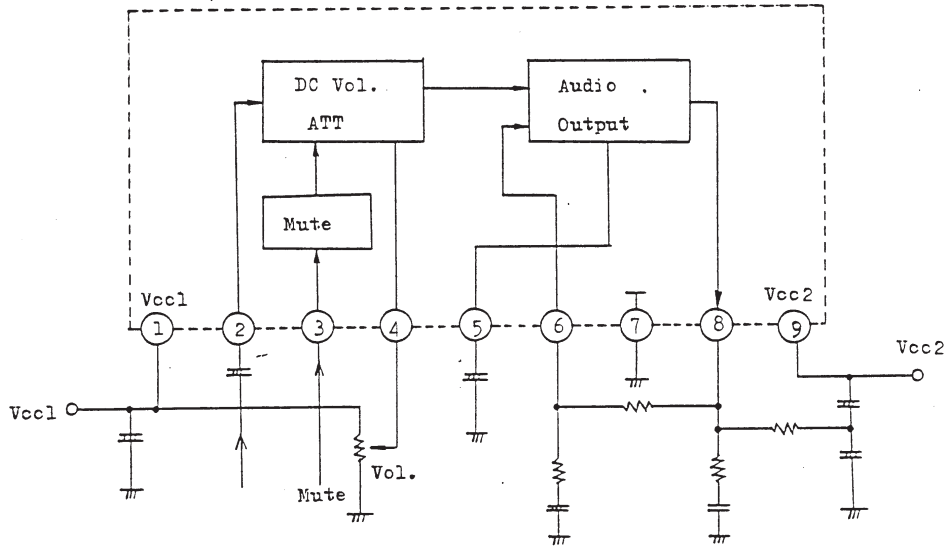

### ● FA5332M <Power Factor Control, IC01>

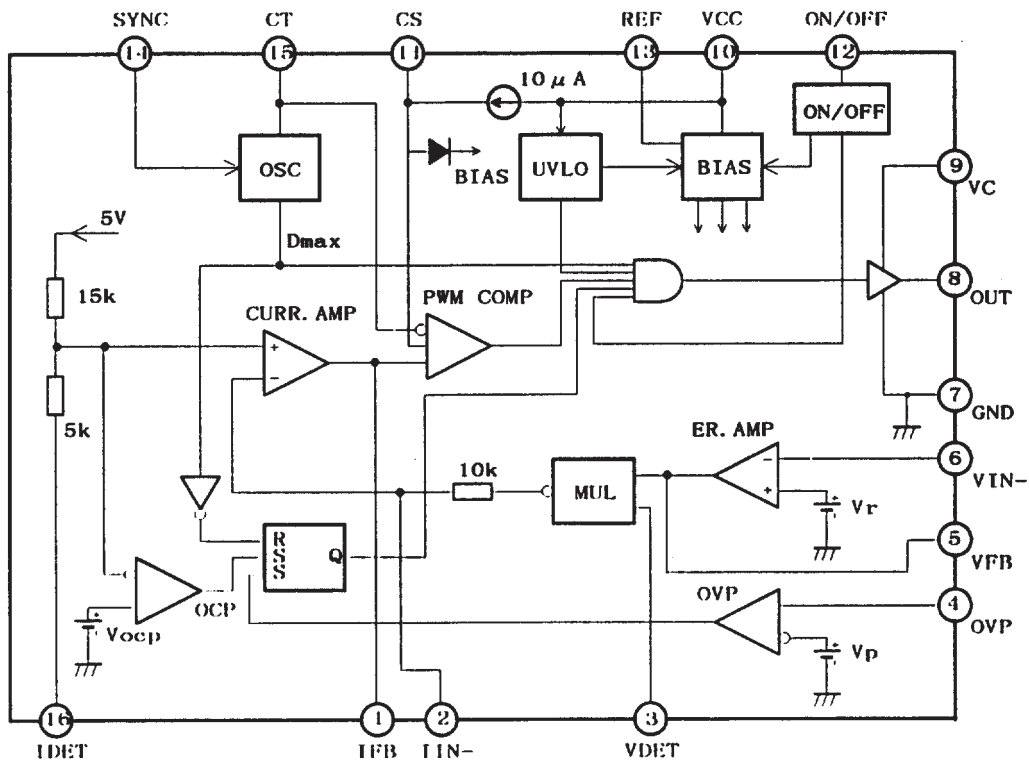

● PW164-10RK <System Control/Scan Converter, IC301>

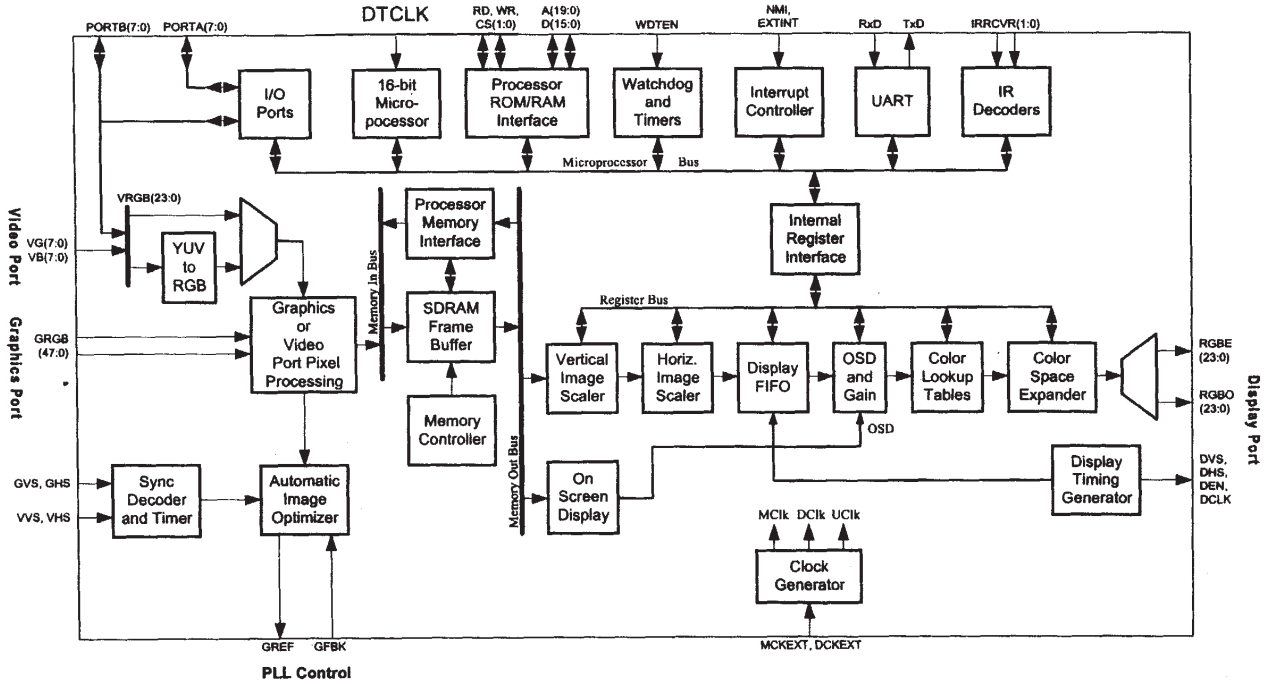

● CXA2111R <LCD Driver, IC401>

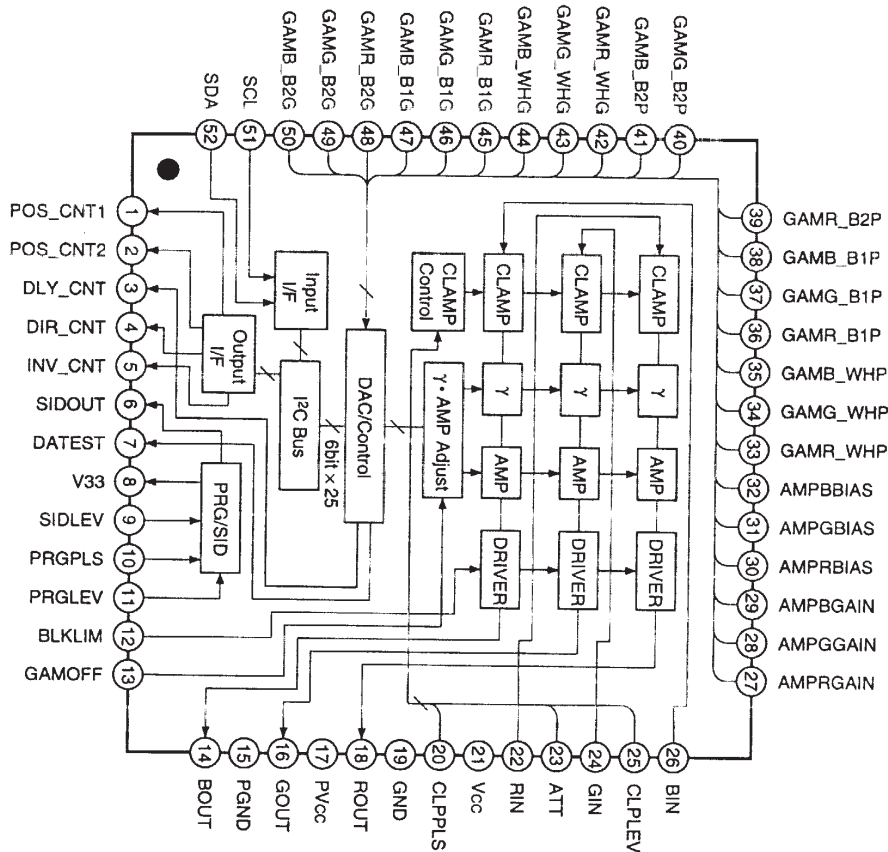

● M62358FP <DAC, IC431>

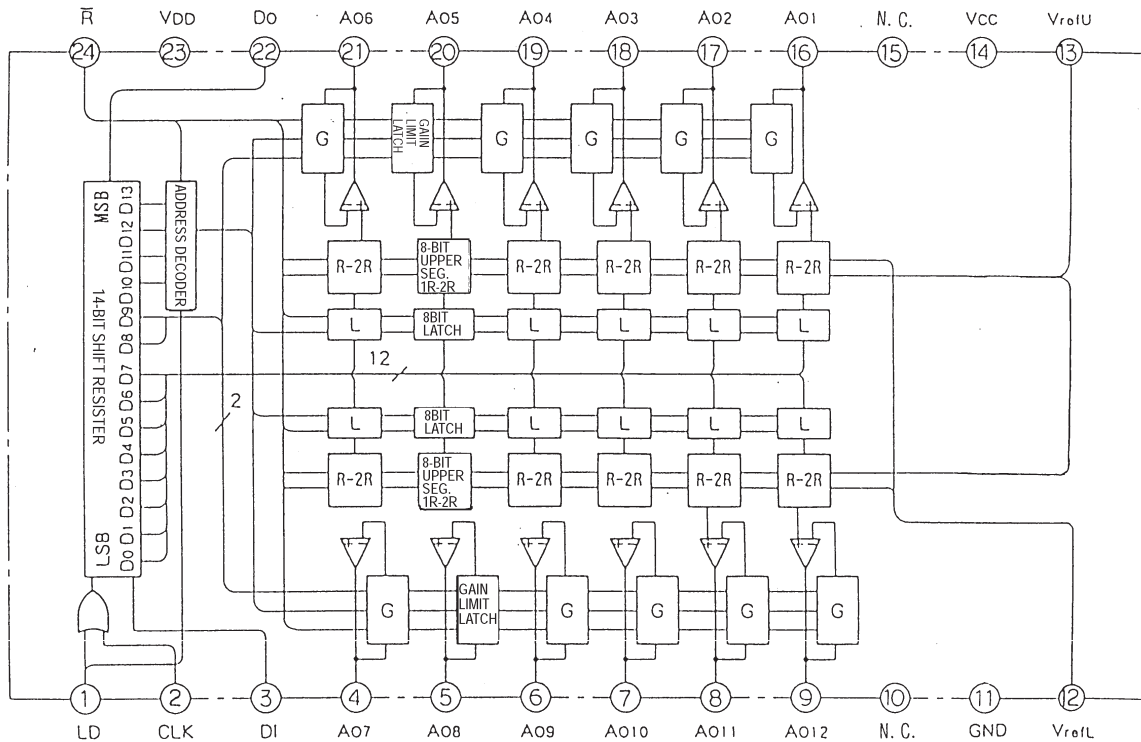

● CXD3503R <White Uniformity Compensation, IC471>

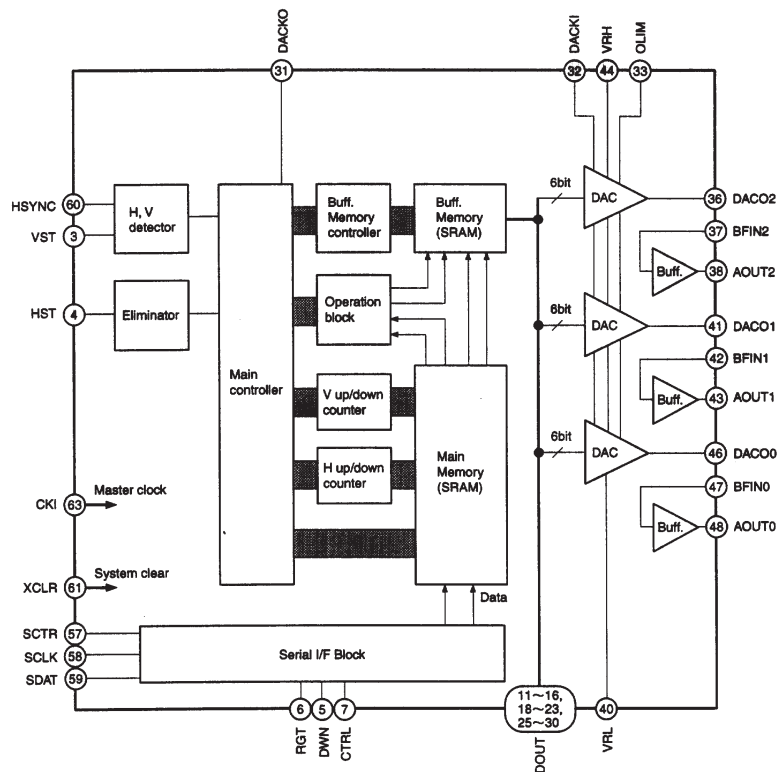

● CXA2112R <Sample & Hold, IC501, IC531, IC561>

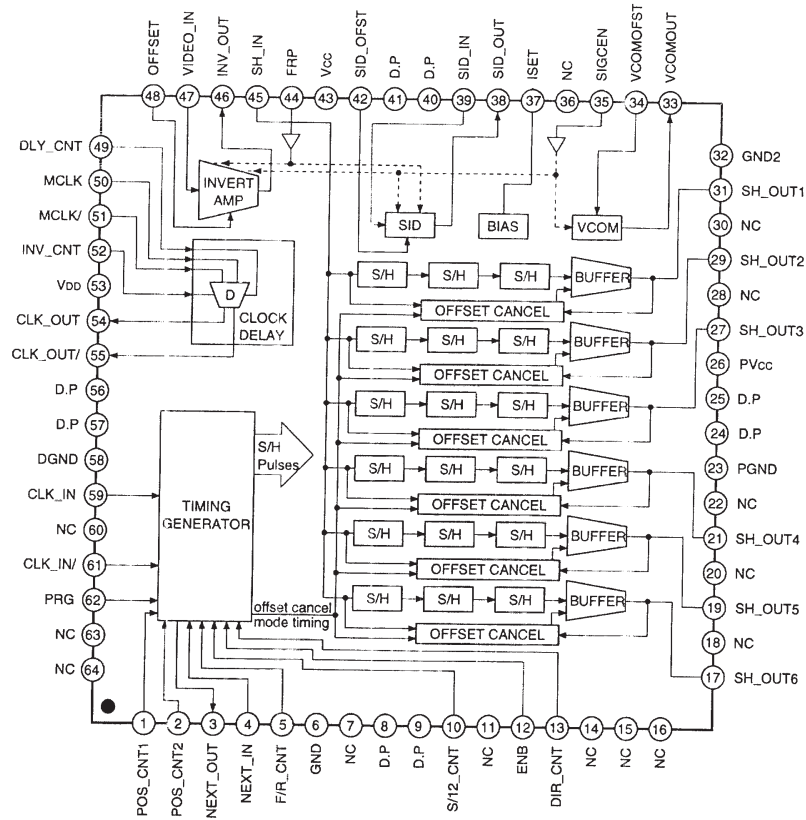

● STR-Z2156 <Power Switching Control, IC631>

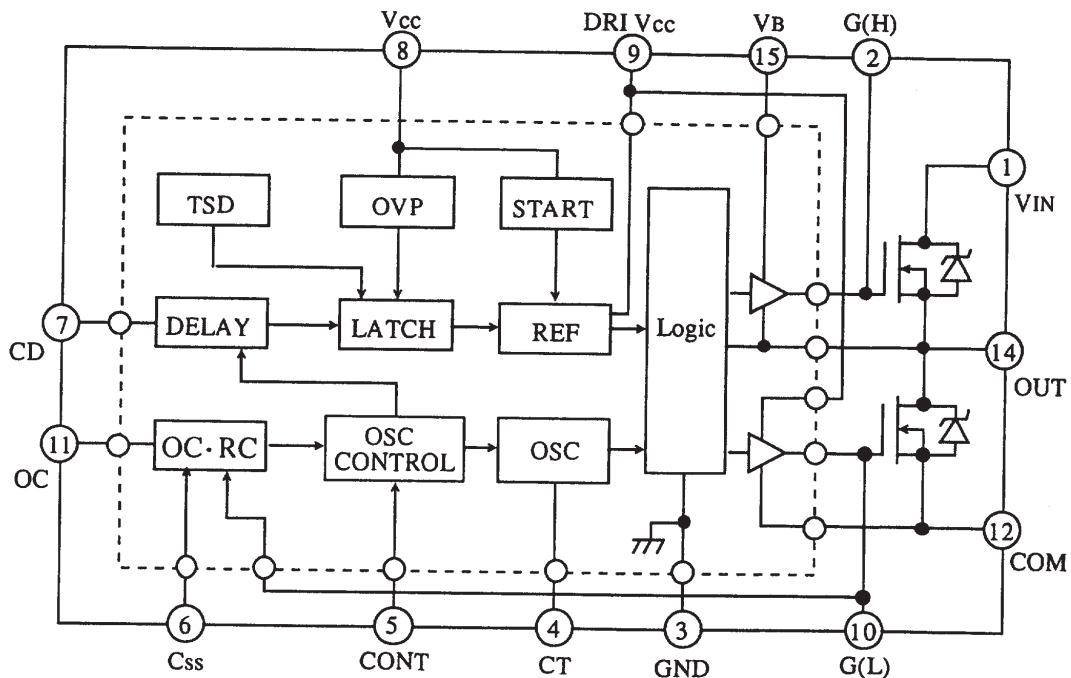

● IDT71V016S <RAM, IC811>

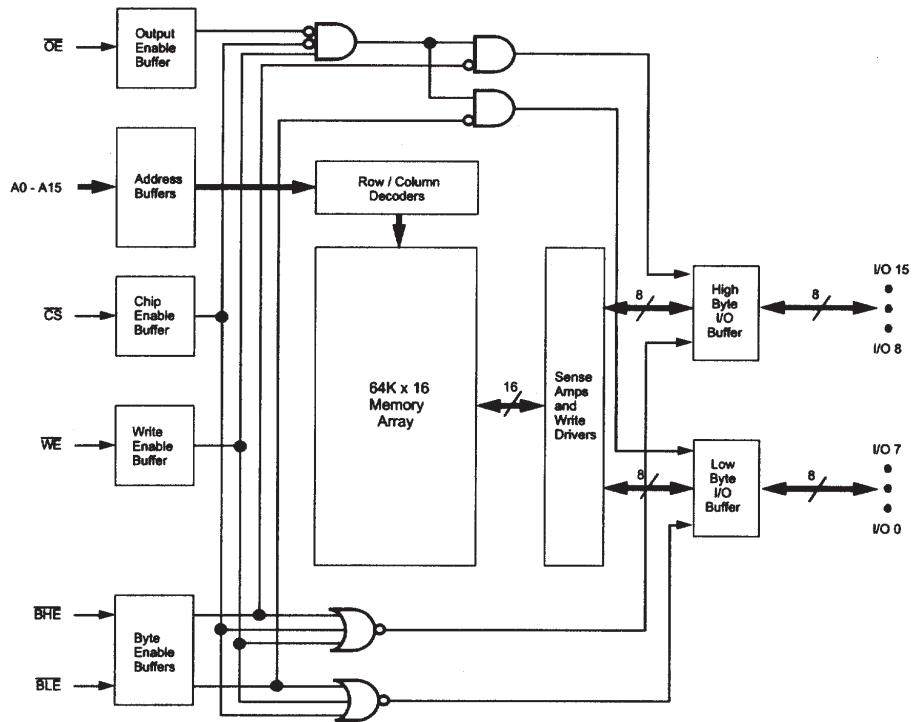

● CXA2016S <Sync Separator, IC1021>

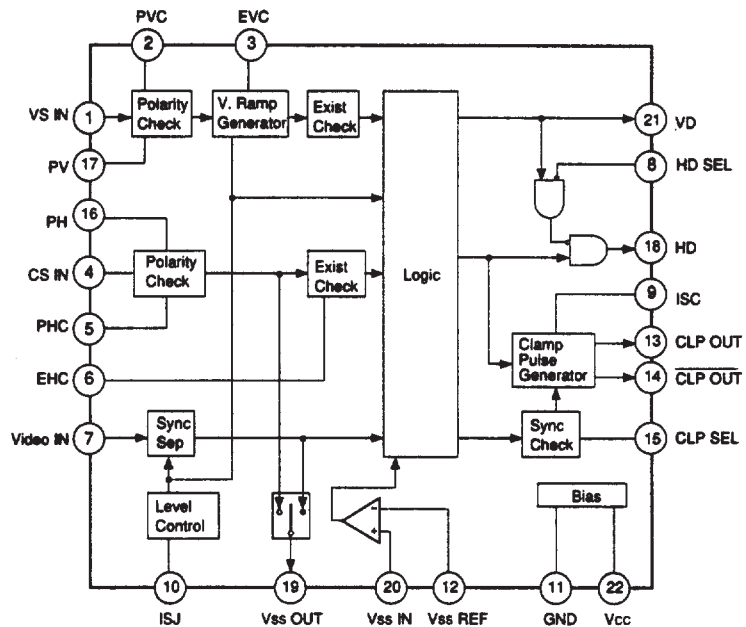



● MC10H351ML <IC1501>

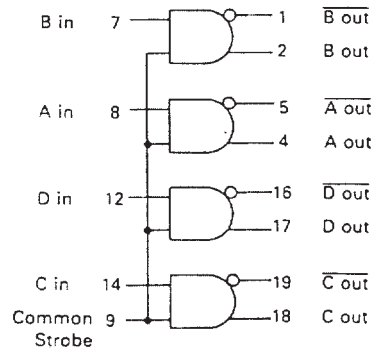

● LM76CHMX <Thermal Sensor, IC1831, IC1832>

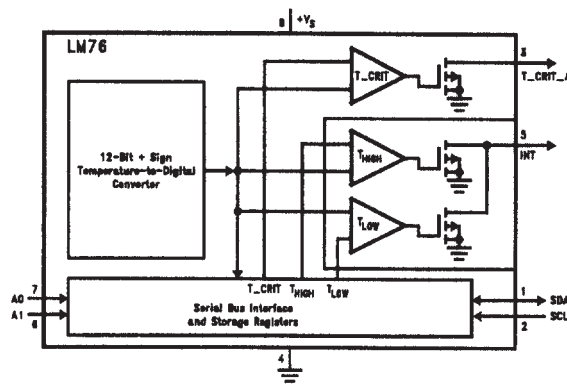

● AV9155C <PLL, IC1961>

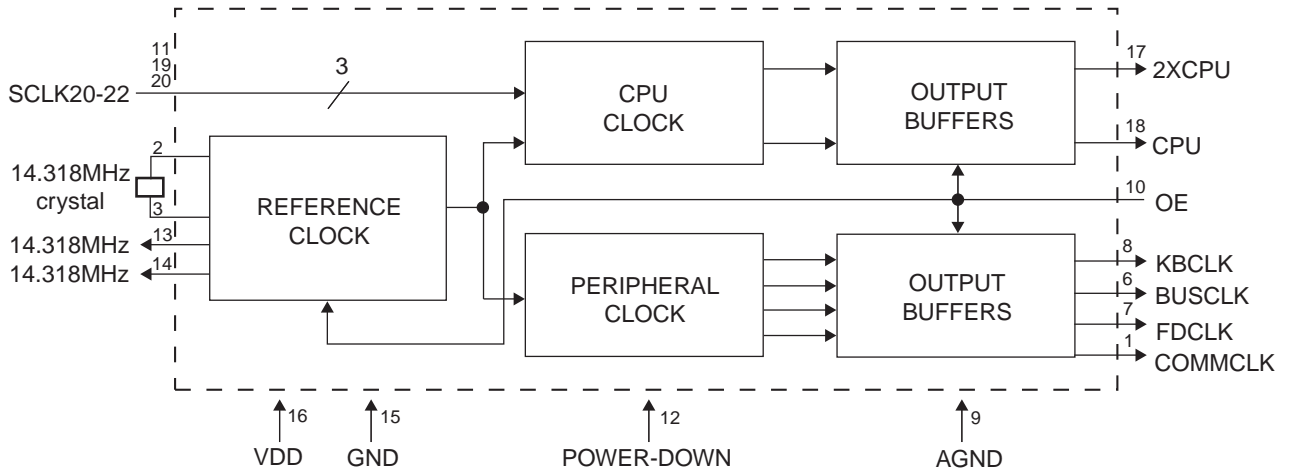

● MB40988PFQ <D/A Converter, IC2200>

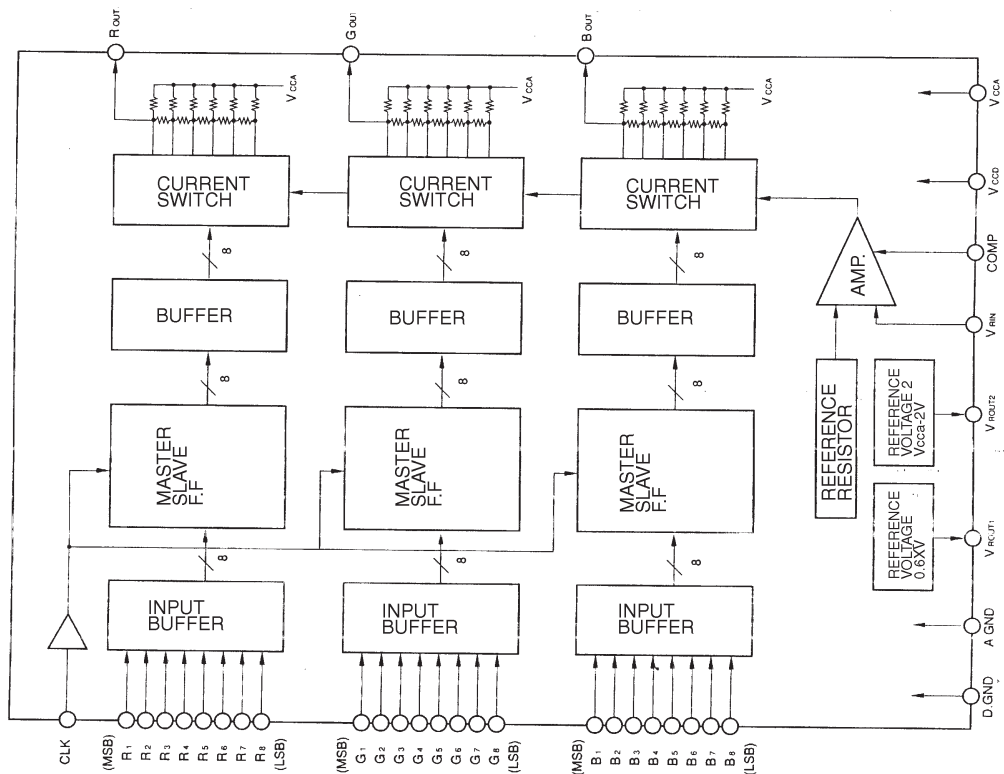

● ET1030F0A <Level Shift, IC3501, IC3531, IC3561>

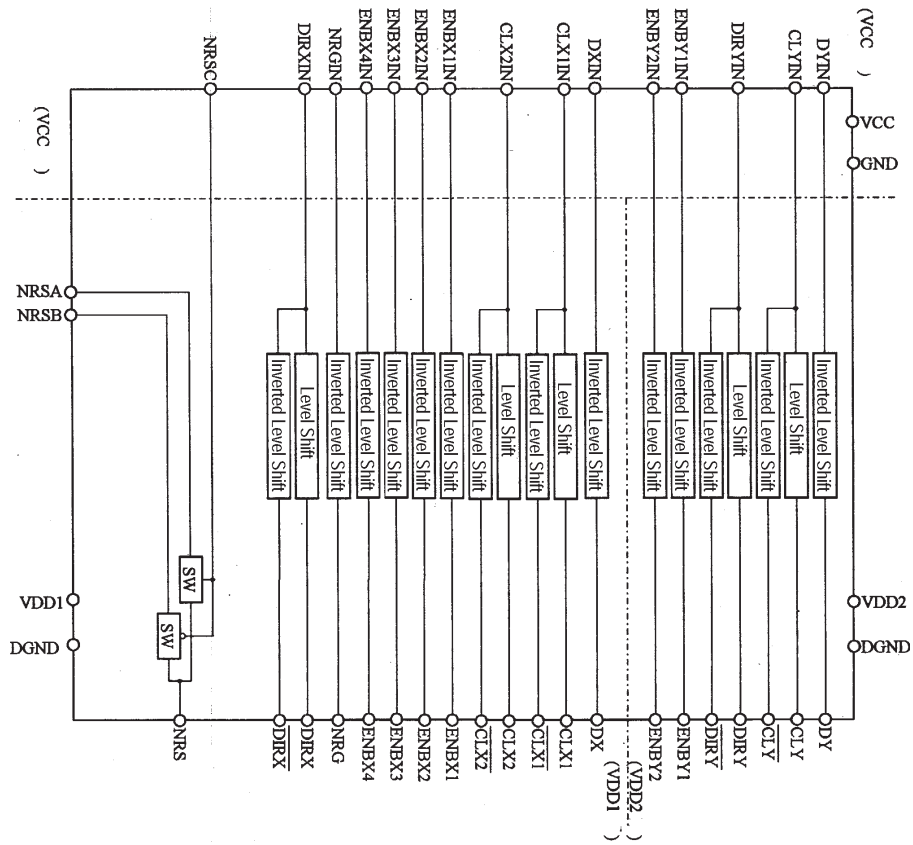

● TC4053BF <Switching, IC5001>

TC4053BP/BF

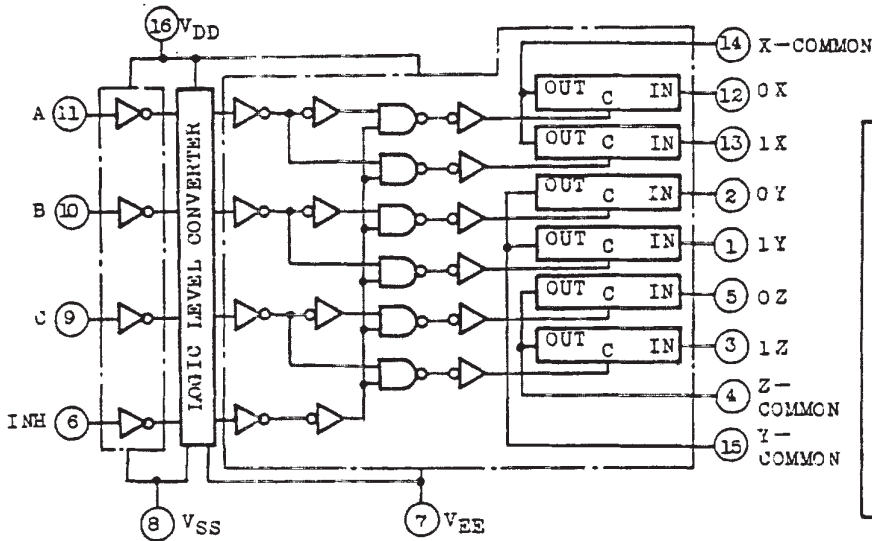

**LOGIC TABLE**

CONTROL	Impedance Between	
C	IN - OUT	*
H		$0.5 \sim 5 \times 10^2 \Omega$
L		$> 10^9 \Omega$

\* See Electrical Characteristics

● SAA7114H <Digital Video Processor, IC5101>

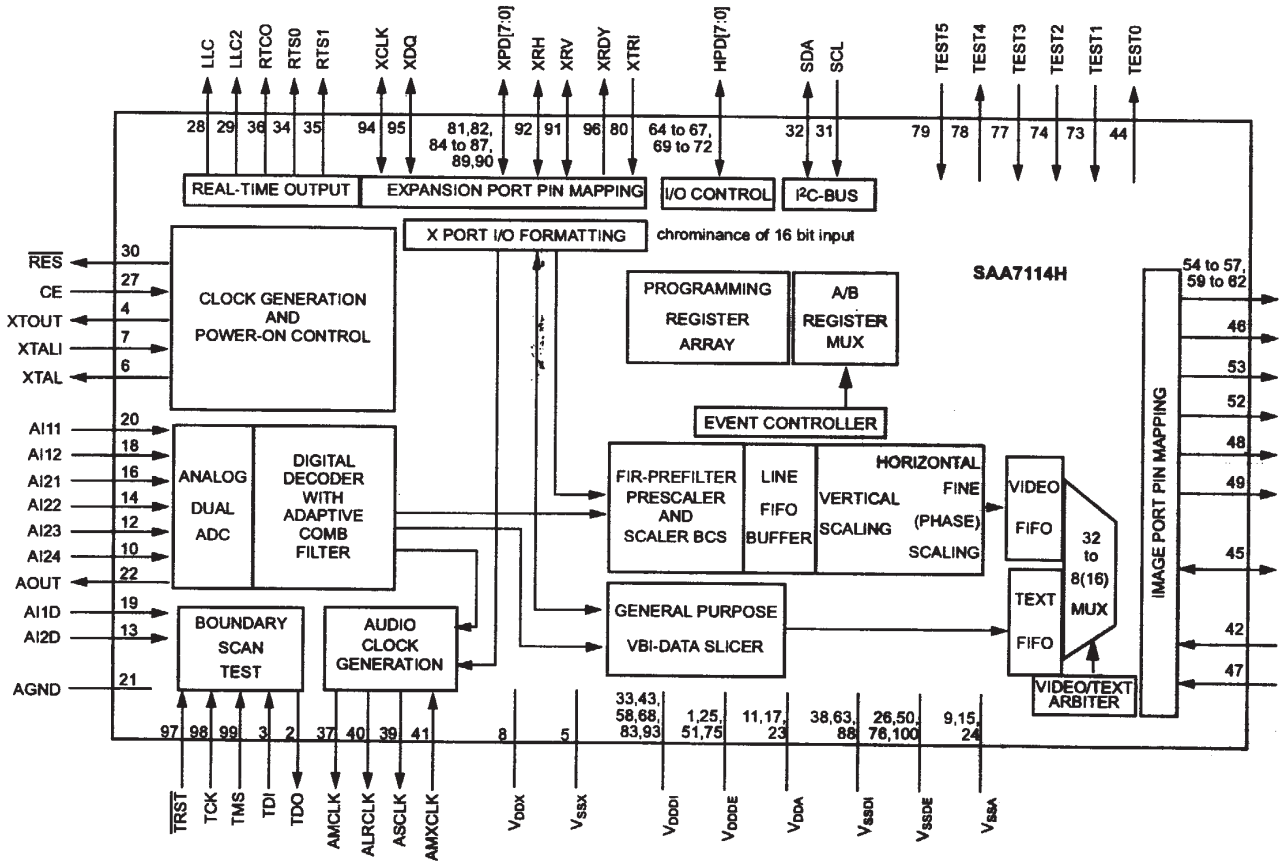

***Part 5***

---

***Parts  
Catalog***





**Multimedia Projector**  
**LV-5110U**  
**LV-5110E**  
**Power Projector**  
**LV-5110J**

**REF.NO.D78-5152**  
**D78-5153**

**D78-5151**

# **PARTS**

# **CATALOG**





CANON LV-5110J  
LV-5110U  
LV-5110E

REF. No. D78-5151  
D78-5152  
D78-5153

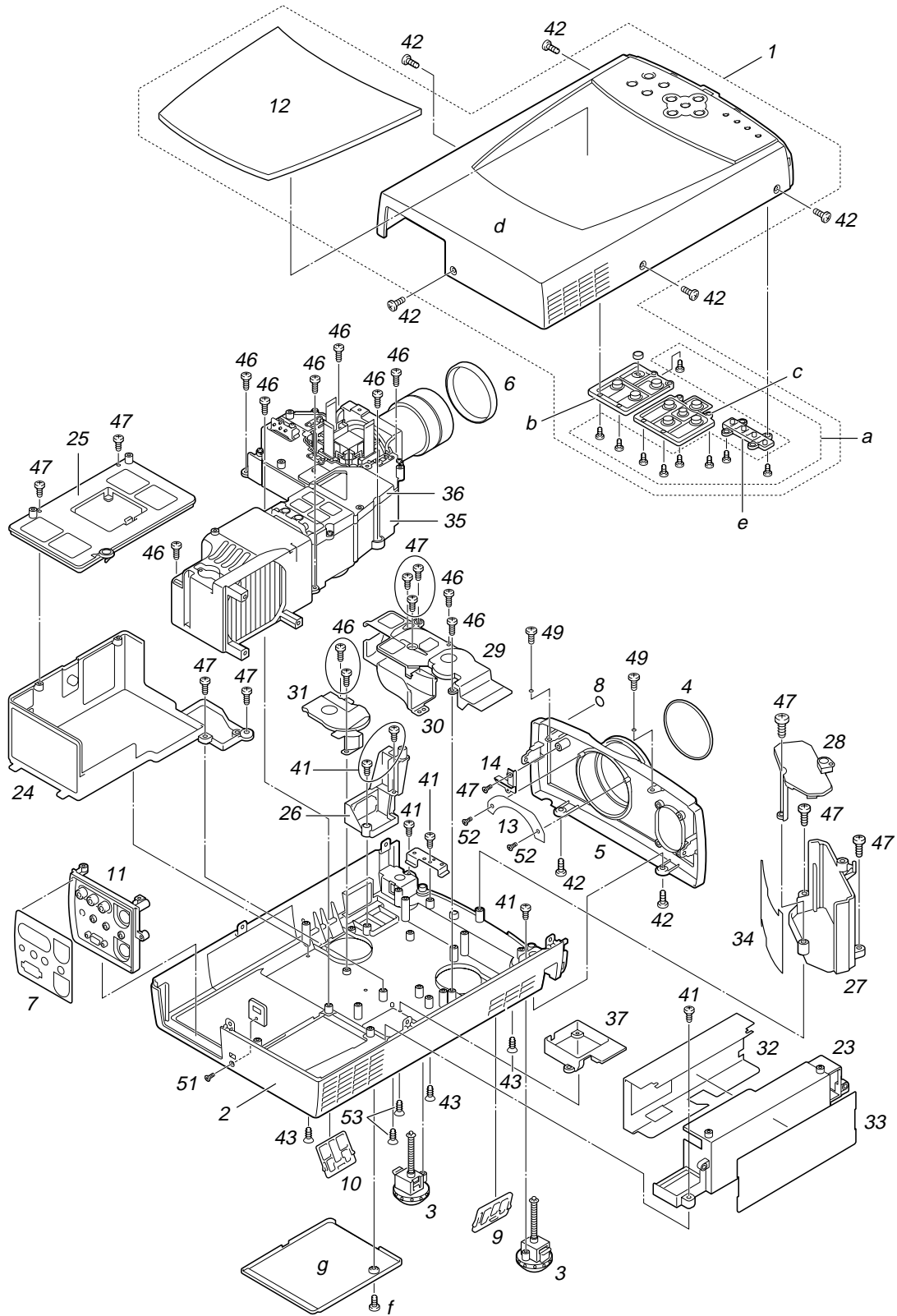

# PARTS LIST

REF.NO. D78-5151  
 D78-5152  
 D78-5153

NEW	SYMBOL	PARTS NO.	CLASS	QTY	DESCRIPTION	REMARKS
*	1	DY4-6122-000	C	1	COVER, TOP	
	2	DY4-6098-000	C	1	COVER, BOTTOM	
	3	DY4-6017-000	C	2	LEG, ASS'Y	
	4	DY4-6018-000	C	1	RING, NAME	
	5	DY4-6019-000	C	1	COVER, FRONT	
*	6	DY4-6120-000	B	1	CAP, LENS	
	7	DY4-6021-000	C	1	PLATE, AV	
	8	DY4-6022-000	C	1	WINDOW, R/C SENSOR	
	9	DY4-6023-000	E	1	FILTER, DUST, L	
	10	DY4-6024-000	E	1	FILTER, DUST, R	
	11	DY4-6025-000	C	1	PANEL, AV	
	12	DY4-6026-000	C	1	PANEL, TOP COVER	
	13	DY4-6027-000	C	1	PLATE, LIGHT SHIELD	
	14	DY4-6028-000	C	1	HOLDER, SENSOR	
	23	DY4-6031-000	C	1	HOLDER, LAMP BALLAST	
	24	DY4-6032-000	C	1	HOLDER, POWER CBA, BOTTOM	
	25	DY4-6033-000	C	1	HOLDER, POWER CBA, TOP	
	26	DY4-6034-000	C	1	HOLDER, AC INLET	
	27	DY4-6035-000	C	1	HOLDER, LINE FILTER, BOTTOM	
	28	DY4-6036-000	C	1	HOLDER, LINE FILTER, TOP	
	29	DY4-6037-000	C	1	DUCT, L, TOP	
	30	DY4-6038-000	C	1	DUCT, L, BOTTOM	
	31	DY4-6039-000	C	1	DUCT, R	
*	32	DY4-6101-000	C	1	SPACER, LAMPBALLAST, R	
	33	DY4-6041-000	C	1	SPACER, LAMPBALLAST, L	
	34	DY4-6042-000	C	1	SPACER, LINE FILTER	
	35	DY4-6043-000	C	1	BASE, OPTICAL BLOCK, BOTTOM	
	36	DY4-6044-000	C	1	BASE, OPTICAL BLOCK, TOP	
	37	DY4-6102-000	C	1	DUCT, FN904	
	41	CY2-8329-000	F	6	SCREW	
	42	DY4-6045-000	F	7	SCREW	
	43	DY4-6046-000	F	3	SCREW	
	46	DY4-5802-000	F	11	SCREW	
	47	DY4-5803-000	F	11	SCREW	
	49	DY4-5801-000	F	2	SCREW	
	51	CY2-8332-000	F	1	SCREW	
	52	DY4-5988-000	F	2	SCREW	
	53	CY2-8231-000	F	2	SCREW	
	a	DY4-5988-000	F	9	SCREW	
	b	DY4-6010-000	C	1	BUTTON ASS'Y, POWER	
	c	DY4-6097-000	C	1	BUTTON ASS'Y, CURSOR	
	e	DY4-6013-000	C	1	WINDOW, LED INDICATOR	
	f	DY4-6045-000	F	1	SCREW	
	g	DY4-6016-000	C	1	COVER, LAMP	

CANON LV-5110J  
LV-5110U  
LV-5110E

REF. No. D78-5151  
D78-5152  
D78-5153

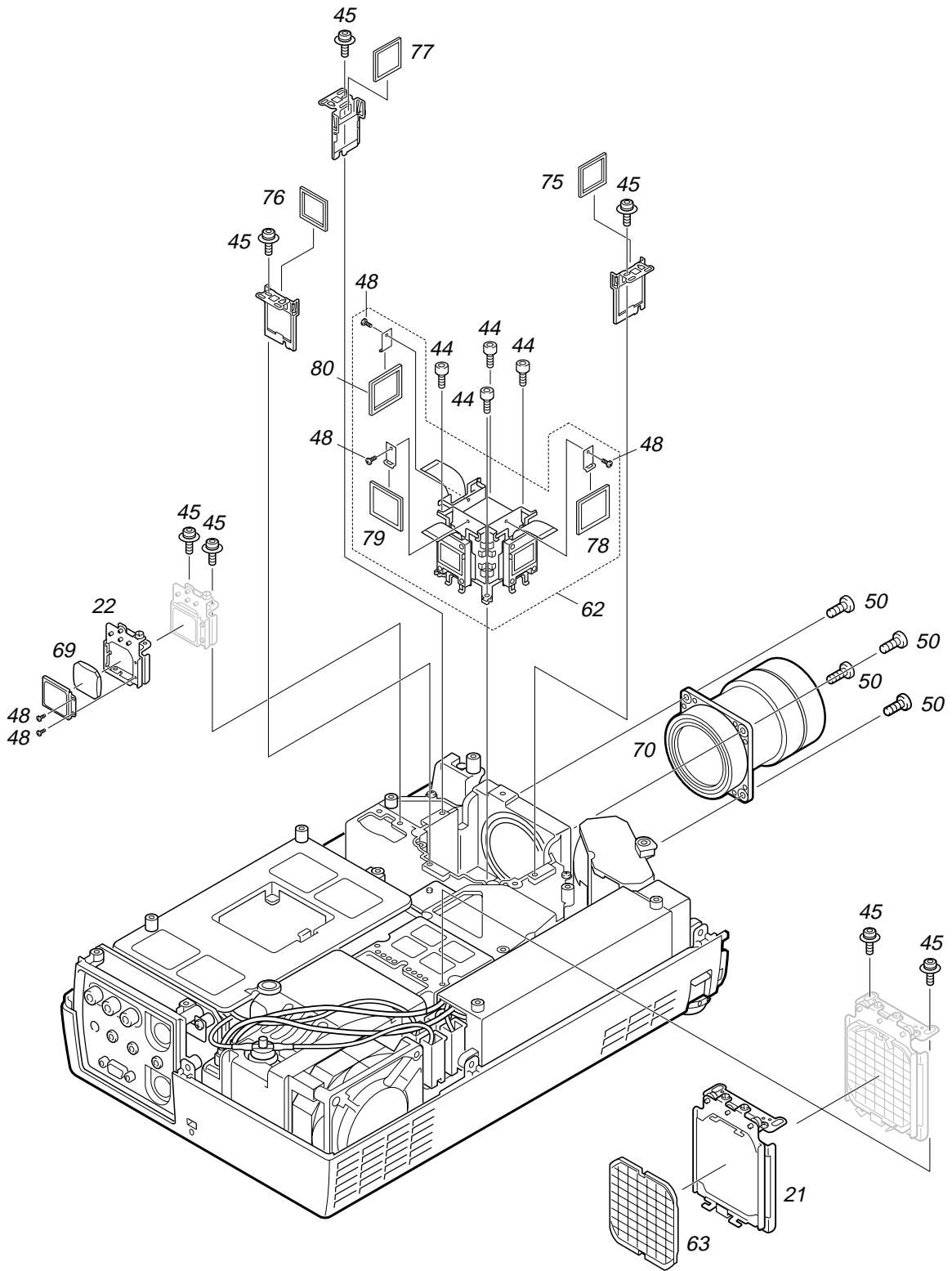

# PARTS LIST

REF.NO. D78-5151  
 D78-5152  
 D78-5153

NEW	SYMBOL	PARTS NO.	CLASS	QTY	DESCRIPTION	REMARKS
	21	DY4-6029-000	C	1	HOLDER, INTEGRATOR IN	
	22	DY4-6030-000	C	1	HOLDER, RELAY OUT	
	44	DY4-6047-000	F	4	SCREW	
	45	DY4-6048-000	F	7	SCREW	
	48	DY4-6049-000	F	5	SCREW	
	50	CY2-8232-000	F	4	SCREW	
	62	DY4-6051-000	C	1	PRISM/LCD ASS'Y	
	63	DY4-6052-000	C	1	LENS, INTEGRATOR IN	
	69	DY4-6058-000	C	1	LENS, RELAY OUT	
	70	DY4-6059-000	C	1	LENS, PROJECTION	
	75	DY4-6064-000	C	1	GLASS, PL IN, R	
	76	DY4-6065-000	C	1	GLASS, PL IN, G	
	77	DY4-6066-000	C	1	GLASS, PL IN, B	
	78	DY4-6067-000	C	1	GLASS, PL OUT, R	
	79	DY4-6068-000	C	1	GLASS, PL OUT, G	
	80	DY4-6069-000	C	1	GLASS, PL OUT, B	

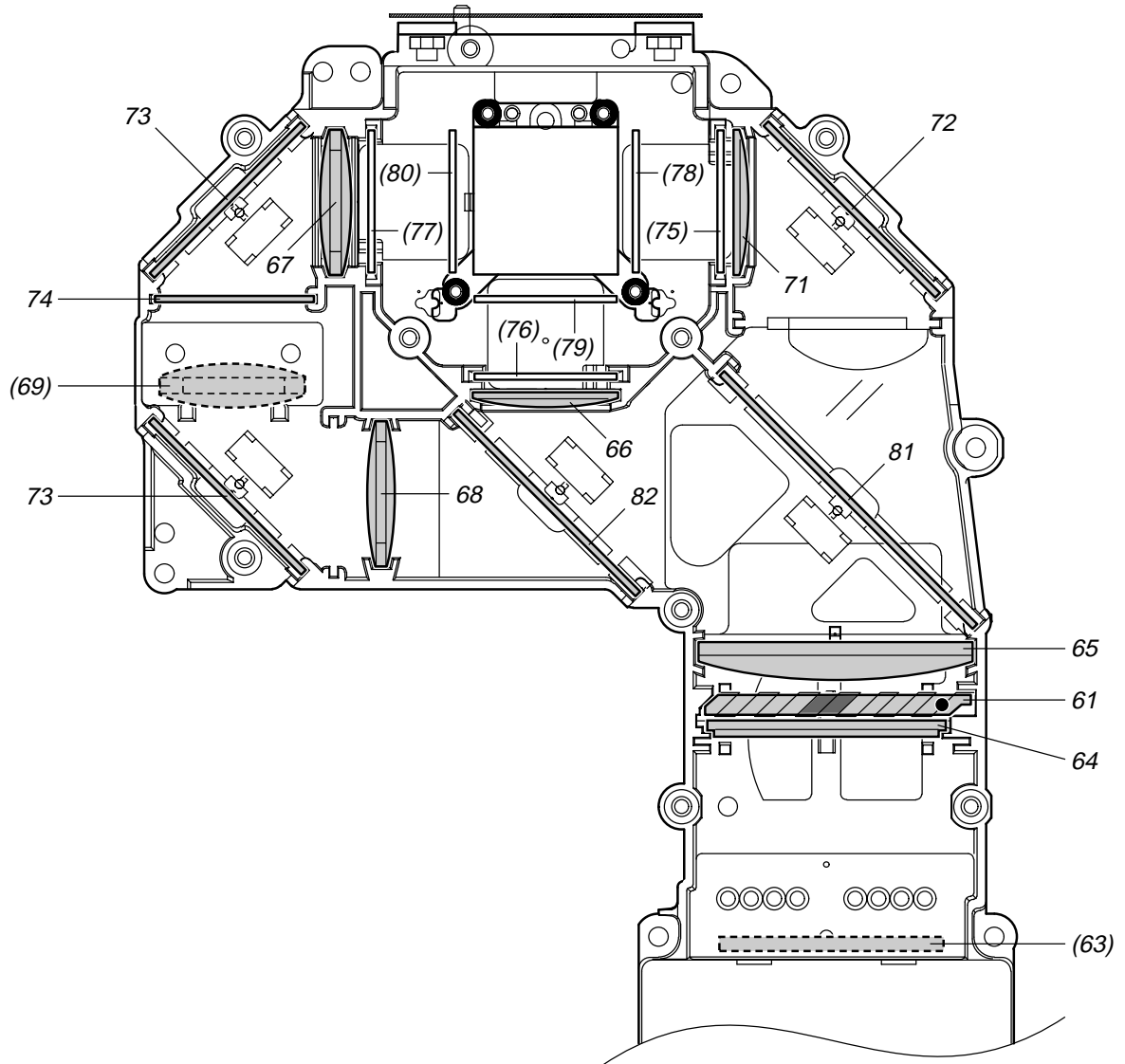

The parts in parentheses are listed on Page 2, too.  
 括弧付の部品は2ページのリストにも記載しています。

# PARTS LIST

REF.NO. D78-5151  
 D78-5152  
 D78-5153

NEW	SYMBOL	PARTS NO.	CLASS	QTY	DESCRIPTION	REMARKS
	61	DY4-6050-000	C	1	PRISM, PBS	
	(63)	DY4-6052-000	C	1	LENS, INTEGRATOR IN	
	64	DY4-6053-000	C	1	LENS, INTEGRATOR OUT	
	65	DY4-6054-000	C	1	LENS, CONDENSER OUT	
	66	DY4-6055-000	C	1	LENS, CONDENSER, G	
	67	DY4-6056-000	C	1	LENS, CONDENSER, B	
	68	DY4-6057-000	C	1	LENS, RELAY IN	
	(69)	DY4-6058-000	C	1	LENS, RELAY OUT	
	71	DY4-6060-000	C	1	LENS, CONDENSER, R	
	72	DY4-6061-000	C	1	MIRROR, R	
	73	DY4-6062-000	C	2	MIRROR, B	
	74	DY4-6063-000	C	1	FILTER, UV	
	(75)	DY4-6064-000	C	1	GLASS, PL IN, R	
	(76)	DY4-6065-000	C	1	GLASS, PL IN, G	
	(77)	DY4-6066-000	C	1	GLASS, PL IN, B	
	(78)	DY4-6067-000	C	1	GLASS, PL OUT, R	
	(79)	DY4-6068-000	C	1	GLASS, PL OUT, G	
	(80)	DY4-6069-000	C	1	GLASS, PL OUT, B	
	81	DY4-6070-000	C	1	MIRROR, DICHROIC, R	
	82	DY4-6071-000	C	1	MIRROR, DICHROIC, G	

CANON LV-5110J  
LV-5110U  
LV-5110E

REF. No. D78-5151  
D78-5152  
D78-5153

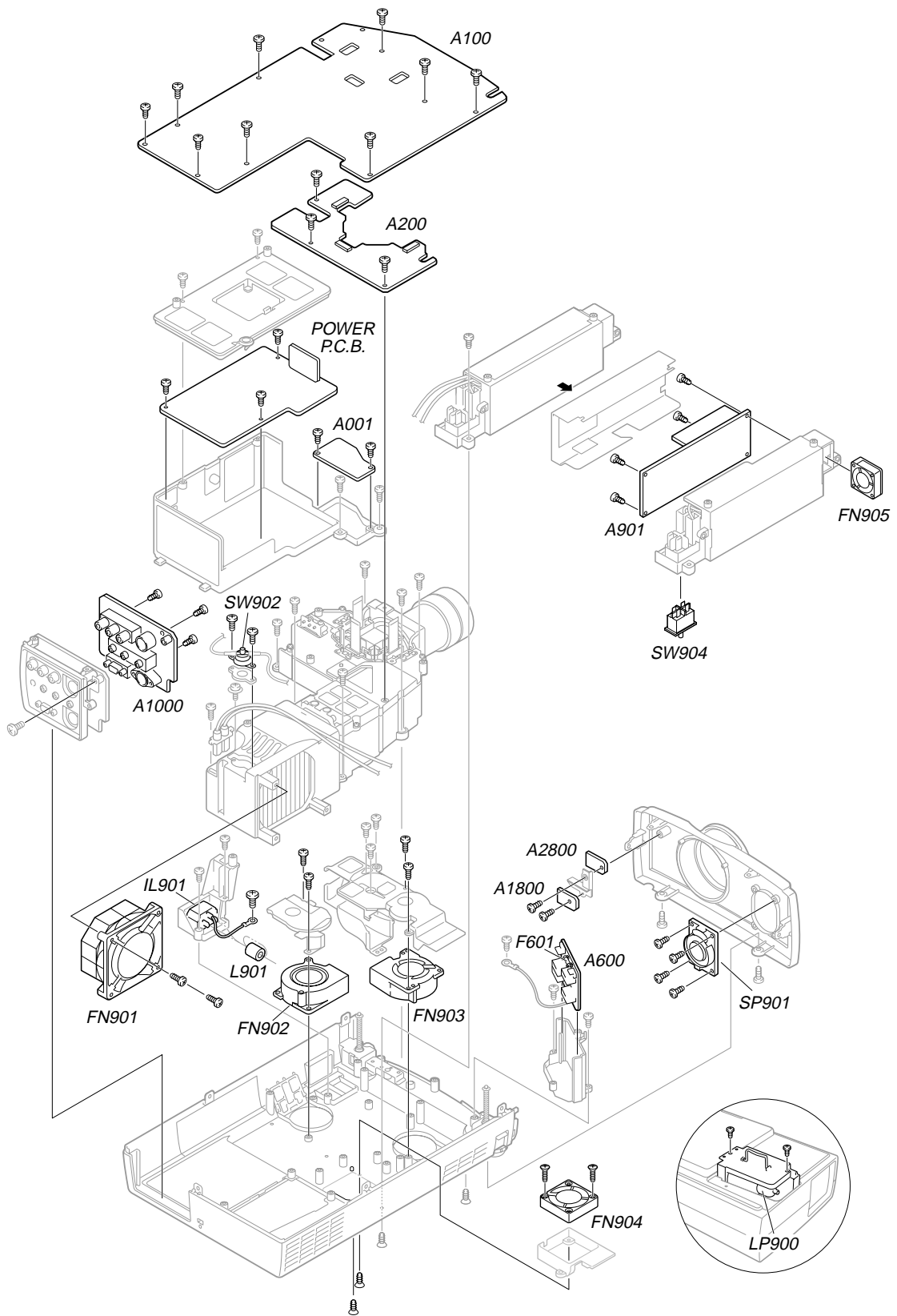

# PARTS LIST

REF.NO. D78-5151  
 D78-5152  
 D78-5153

NEW	SYMBOL	PARTS NO.	CLASS	QTY	DESCRIPTION	REMARKS
	A001	DY4-6088-000	C	1	PCB ASS'Y, AUDIO	
*	A100	DY4-6123-000	C	1	PCB ASS'Y, MAIN	
*	A200	DY4-6121-000	C	1	PCB ASS'Y, COMPONENT	
	A600	DY4-6089-000	D	1	PCB ASS'Y, LINE FILTER	
	A901	DY4-6106-000	D	1	LAMP BALLAST ASS'Y	
	A1000	DY4-6085-000	C	1	PCB ASS'Y, AV	
	A1800	DY4-6084-000	C	1	PCB ASS'Y, TEMP	
	A2800	DY4-6087-000	C	1	PCB ASS'Y, R/C	
	POWER	DY4-6090-000	D	1	PCB ASS'Y, POWER	
	F601	CY2-8376-000	D	1	FUSE	250V 4A
	FN901	DY4-6075-000	D	1	FAN, FN901	
*	FN902	DY4-6124-000	D	1	FAN, FN902/FN903	
*	FN903	DY4-6124-000	D	1	FAN, FN902/FN903	
	FN904	DY4-6107-000	D	1	FAN, FN904	
	FN905	DY4-6078-000	D	1	FAN, FN905	
	IL901	DY4-6079-000	D	1	SOCKET, AC INLET	
	L901	DY4-6081-000	C	1	FERRITE CORE	
	LP900	DY4-6108-000	E	1	LAMP ASS'Y, LV-LP10	
	SP901	CY2-8274-000	C	1	SPEAKER	
	SW902	CY2-8382-000	D	1	SWITCH, THERMAL	
	SW904	CY2-8277-000	D	1	SWITCH, PUSH	



CANON LV-5110J  
LV-5110U  
LV-5110E

REF. No. D78-5151  
D78-5152  
D78-5153

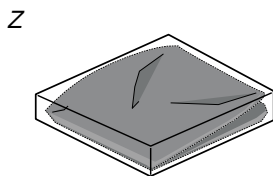
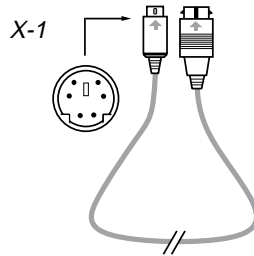
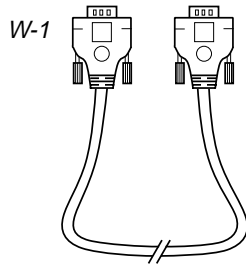
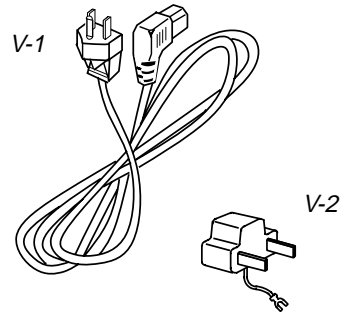
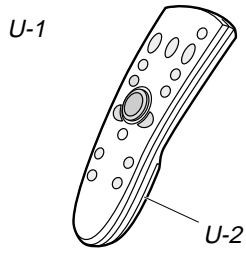

# PARTS LIST

REF.NO. D78-5151  
 D78-5152  
 D78-5153

NEW	SYMBOL	PARTS NO.	CLASS	QTY	DESCRIPTION	REMARKS
	U-1	DY4-6072-000	C	1	REMOTE CONTROLLER, LV-5100	
	U-2	DY4-5859-000	B	1	COVER, REMO-CON BATTERY	
	V-1	CY2-8293-000	D	1	POWER CORD, AC120V	FOR LV-5110U
	V-1	CY2-8295-000	D	1	POWER CORD, AC240V	FOR LV-5110E
	V-1	CY2-8299-000	D	1	POWER CORD, AC100V	FOR LV-5110J
	V-2	CY2-8288-000	C	1	ADAPTER, POWER PLUG	FOR LV-5110J
	W-1	CY2-8298-000	C	1	INTERFACE CABLE, VGA	
	X-1	DY4-5909-000	C	1	CABLE, MOUSE CONTROL PS/2	
	Z	DY4-6105-000	C	1	BAG, CARRYING	

# PARTS LIST

REF.NO. D78-5151  
 D78-5152  
 D78-5153

PAGE	NEW	SYMBOL	PARTS NO.	QTY	PAGE	NEW	SYMBOL	PARTS NO.	QTY
1		53	CY2-8231-000	2	1		28	DY4-6036-000	1
2		50	CY2-8232-000	4	1		29	DY4-6037-000	1
4		SP901	CY2-8274-000	1	1		30	DY4-6038-000	1
4		SW904	CY2-8277-000	1	1		31	DY4-6039-000	1
5		V-2	CY2-8288-000	1	1		33	DY4-6041-000	1
5		V-1	CY2-8293-000	1	1		34	DY4-6042-000	1
5		V-1	CY2-8295-000	1	1		35	DY4-6043-000	1
5		W-1	CY2-8298-000	1	1		36	DY4-6044-000	1
5		V-1	CY2-8299-000	1	1	42, f	DY4-6045-000	8	
1		41	CY2-8329-000	6	1		43	DY4-6046-000	3
1		51	CY2-8332-000	1	2		44	DY4-6047-000	4
4		F601	CY2-8376-000	1	2		45	DY4-6048-000	7
4		SW902	CY2-8382-000	1	2		48	DY4-6049-000	5
1		49	DY4-5801-000	2	2		61	DY4-6050-000	1
1		46	DY4-5802-000	11	2		62	DY4-6051-000	1
1		47	DY4-5803-000	11	3		63	DY4-6052-000	1
5		U-2	DY4-5859-000	1	3		64	DY4-6053-000	1
5		X-1	DY4-5909-000	1	3		65	DY4-6054-000	1
1		52, a	DY4-5988-000	11	3		66	DY4-6055-000	1
1		b	DY4-6010-000	1	3		67	DY4-6056-000	1
1		e	DY4-6013-000	1	2		68	DY4-6057-000	1
1		g	DY4-6016-000	1	2, (3)		69	DY4-6058-000	1
1		3	DY4-6017-000	2	2		70	DY4-6059-000	1
1		3	DY4-6018-000	1	3		71	DY4-6060-000	1
1		5	DY4-6019-000	1	3		72	DY4-6061-000	1
1		7	DY4-6021-000	1	3		73	DY4-6062-000	2
1		8	DY4-6022-000	1	3		74	DY4-6063-000	1
1		9	DY4-6023-000	1	2, (3)		75	DY4-6064-000	1
1		10	DY4-6024-000	1	2, (3)		76	DY4-6065-000	1
1		11	DY4-6025-000	1	2, (3)		77	DY4-6066-000	1
1		12	DY4-6026-000	1	2, (3)		78	DY4-6067-000	1
1		13	DY4-6027-000	1	2, (3)		79	DY4-6068-000	1
1		14	DY4-6028-000	1	2, (3)		80	DY4-6069-000	1
2		21	DY4-6029-000	1	3		81	DY4-6070-000	1
2		22	DY4-6030-000	1	3		82	DY4-6071-000	1
1		23	DY4-6031-000	1	5	U-1	DY4-6072-000	1	
1		24	DY4-6032-000	1	4	FN901	DY4-6075-000	1	
1		25	DY4-6033-000	1	4	FN905	DY4-6078-000	1	
1		26	DY4-6034-000	1	4	IL901	DY4-6079-000	1	
1		27	DY4-6035-000	1	4	L901	DY4-6081-000	1	

# PARTS LIST

REF.NO. D78-5151  
 D78-5152  
 D78-5153

PAGE	NEW	SYMBOL	PARTS NO.	QTY
4		A1800	DY4-6084-000	1
4		A1000	DY4-6085-000	1
4		A2800	DY4-6087-000	1
4		A001	DY4-6088-000	1
4		A600	DY4-6089-000	1
4		POWER	DY4-6090-000	1
1		c	DY4-6097-000	1
1		2	DY4-6098-000	1
1		32	DY4-6101-000	1
1		37	DY4-6102-000	1
5		Z	DY4-6105-000	1
4		A901	DY4-6106-000	1
4		FN904	DY4-6107-000	1
4		LP900	DY4-6108-000	1
1	*	6	DY4-6120-000	1
4	*	A200	DY4-6121-000	1
1	*	1	DY4-6122-000	1
4	*	A900	DY4-6123-000	1
4	*	FN902/FN903	DY4-6124-000	1



# *Part 6*

---

# *Electrical Diagrams*



# 1. PARTS DESCRIPTION AND READING IN SCHEMATIC DIAGRAM

1. The parts specification of resistors, capacitors and coils are expressed in designated code. Please check the parts description by the following code table.
2. Some of transistors and diodes are indicated in mark for the substitution of parts name. Please check the parts name by the following code table.
3. Voltages and waveforms were taken with a video color bar signal (1Vp-p at 75 ohms terminated) and controls to normal.
4. Voltages were taken with a high-impedance digital voltmeter.

## Capacitor Reading

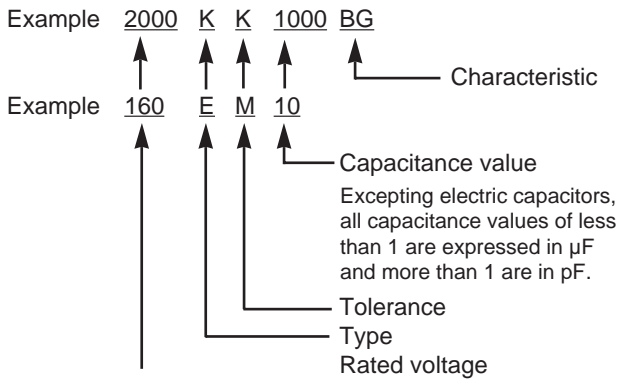

● Material table

Mark	Material
E	Electrolytic
P	Electrolytic (non-polarized)
C	Ceramic (temperature compensation)
K	Ceramic
F	Polyester
N	Polypropylene
M	Metalized polypropylene
H	Metalized polypropylar
B	Ceramic (semiconductor)
G	Metalized polyester
Y	Composite film
S	Styrol
T	Tantalum oxide solid electrolytic
U	Organic semiconductive electrolyte
D	Electric double layer electrolytic

● Tolerance table

Mark	Tolerance
A	not specified
B	$\pm 0.1$
C	$\pm 0.25$
D	$\pm 0.5$
F	$\pm 1$
G	$\pm 2$
E	$\pm 2.5$
H	$\pm 3$
J	$\pm 5$
K	$\pm 10$
M	$\pm 20$
N	$\pm 30$
P	+100 -0
Q	+30 -10
T	+50 -10
U	+75 -10
V	+20 -10
W	+100 -10
X	+40 -20
Y	+150 -10
Z	+80 -20

## Coil Reading

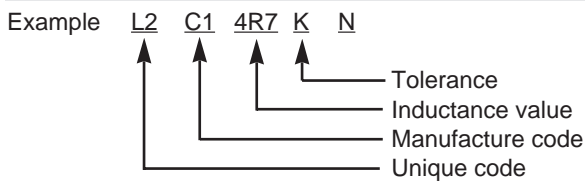

Mark	Tolerance (nH)	Mark	Tolerance (%)
C	$\pm 0.25$	G	$\pm 2$
D	$\pm 0.5$	J	$\pm 5$
S	$\pm 0.3$	K	$\pm 10$
A	$\pm 0.2$	L	$\pm 15$
		M	$\pm 20$



### Resistor Reading

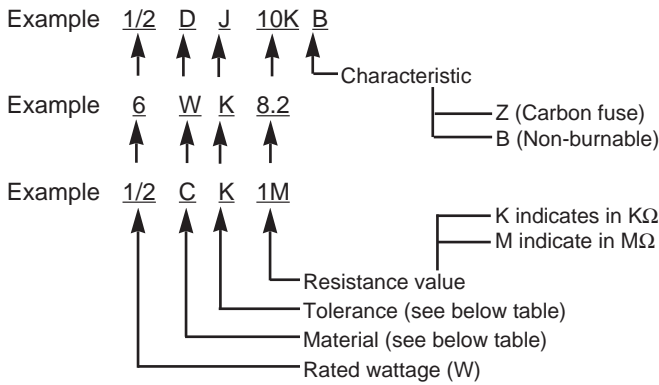

● Material table

Mark	Material
D	Carbon
N	Metal film
S	Oxide metal film
C	Solid
G	Metal glaze
W	Wire winding or cement
H	Ceramic
F	Fusible

● Tolerance table

Mark	Tolerance
A	±0.05
B	±0.1
C	±0.25
D	±0.5
F	±1
G	±2
J	±5
K	±10
M	±20
P	+5 -15
Z	used in 0 ohm

**Note:** Resistor which is indicated with resistance value only are 1/6W carbon resistor. Resistor which is indicated with material, tolerance and value are 1/4W rated wattage.

### Diode/Transistor Type Reading

● Diode

Mark	Type number
R	1S2076A, 1S2473, 1N4148
AA	1S2076A, 1S2473, 1SS133, 1N4148

● Transistor

(1) NPN type

Mark	Type number			
--	2SC536	2SC945A	2SC1815	2SC1740S
AD	NF, NG	PA, QA, RA	Y, GR	Q, R, S
AE	NF, NG	PA, QA	O, Y, GR	Q, R, S

(2) PNP type

Mark	Type number			
--	2SA608	2SA564A	2SA1015	2SA933S
AB	NF	R	Y, GR	R
AC	NF	Q, R	O, Y, GR	Q, R

(3) Chip type

Mark	Type number				
--	2SA1179	2SA1037K	2SA1037AK	2SC2812	2SC2412K
AJ	M6, M7	R, S	R, S		
AH				L6, L7	R, S

## 2. PIN DESCRIPTION OF DIODE, TRANSISTOR AND IC

### ● Diode

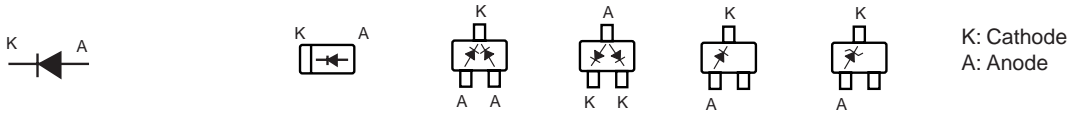

### ● Transistor/FET

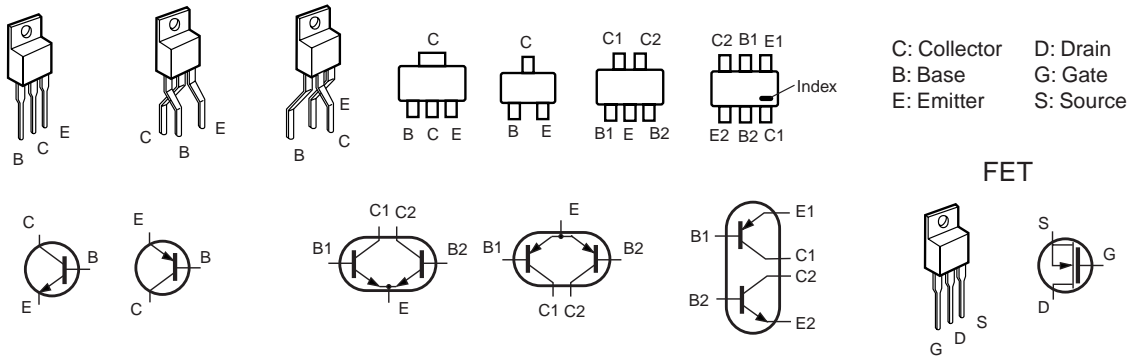

### ● IC

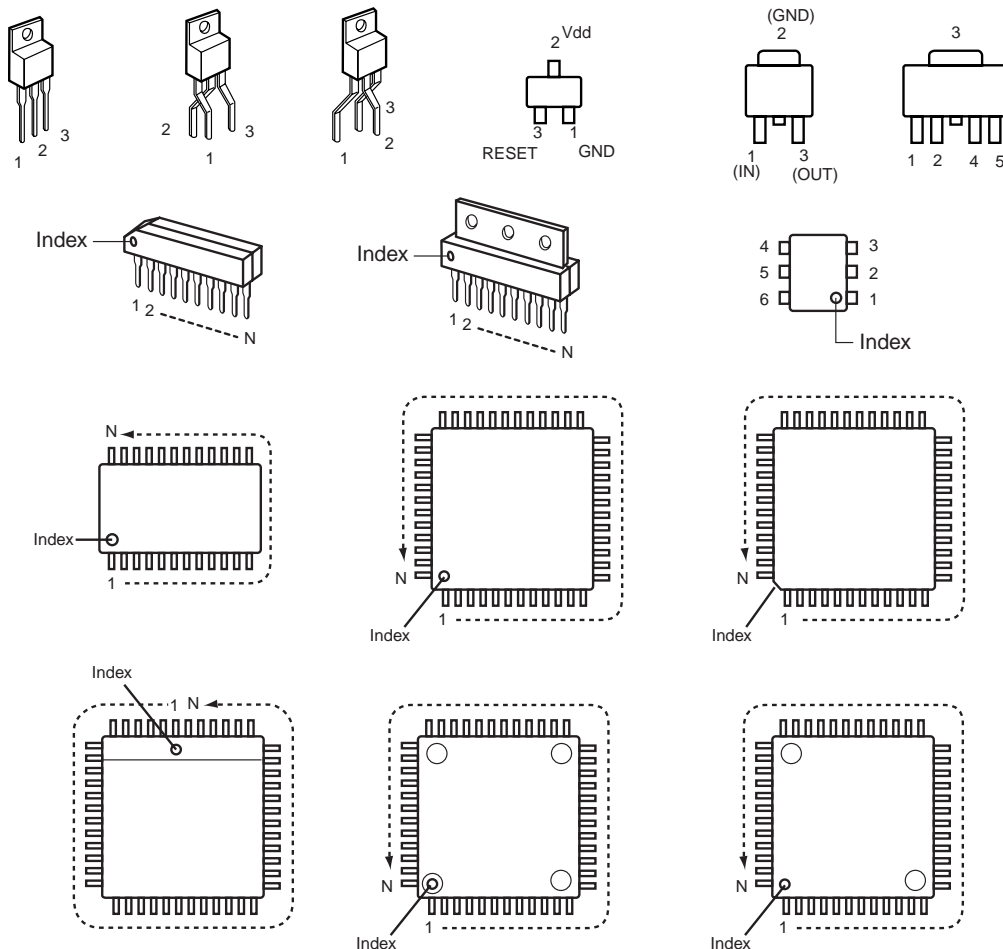

# ■ Circuit Block Diagram (LV-5110E/LV-5110U)

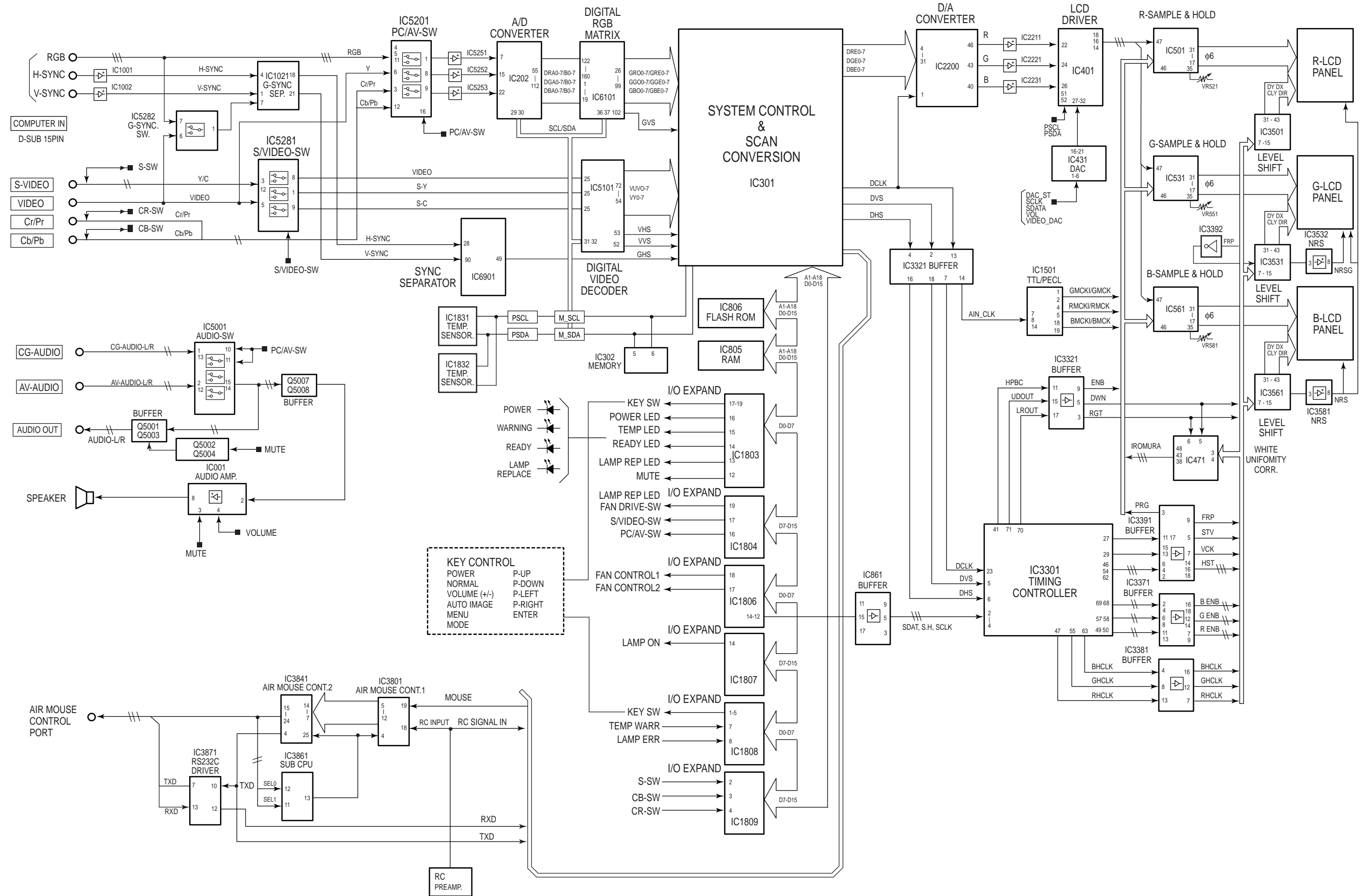

# Power Supply Lines (LV-5110E/LV-5110U)

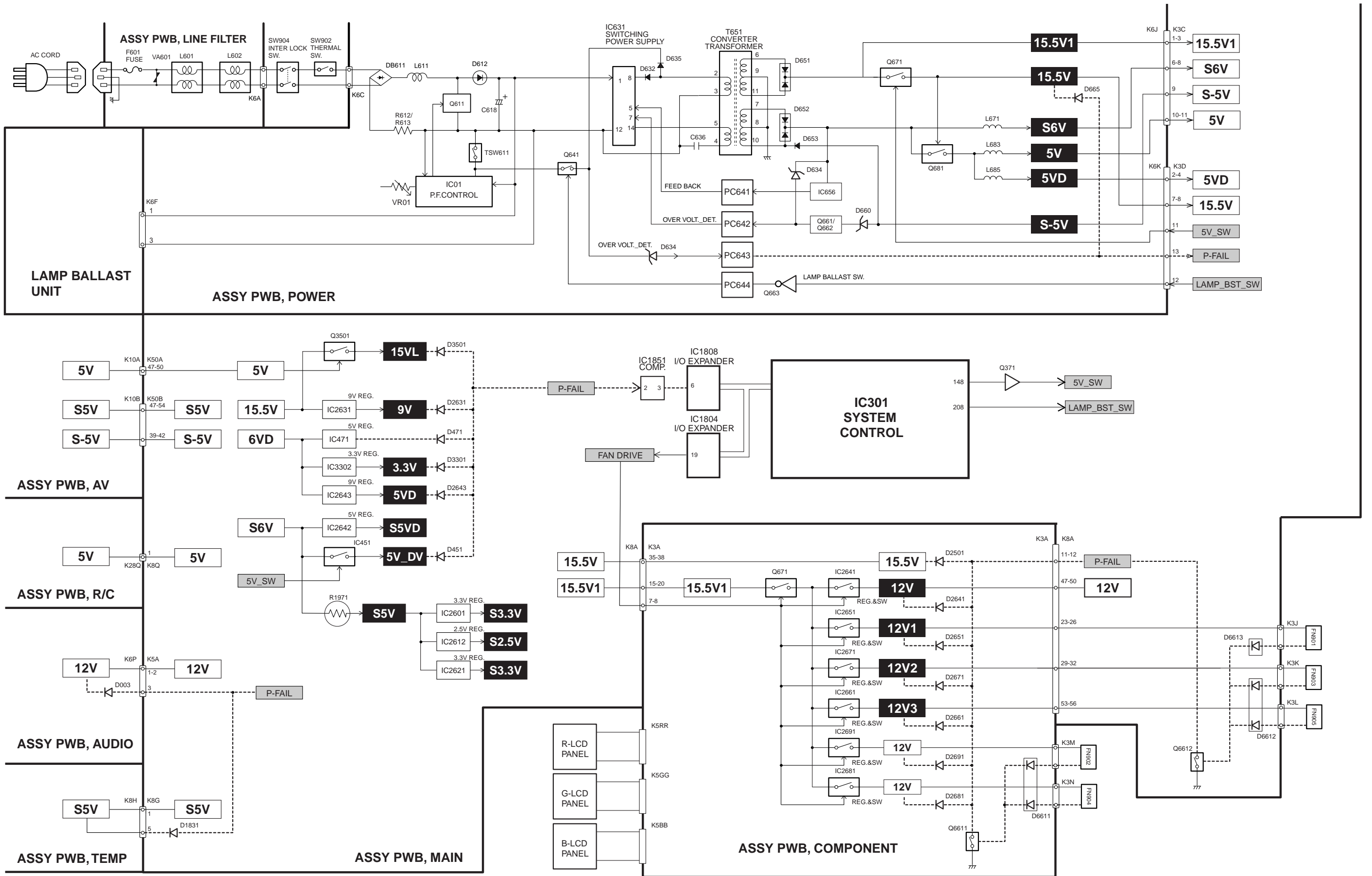

■ Schematic Diagrams LV-5110U/E

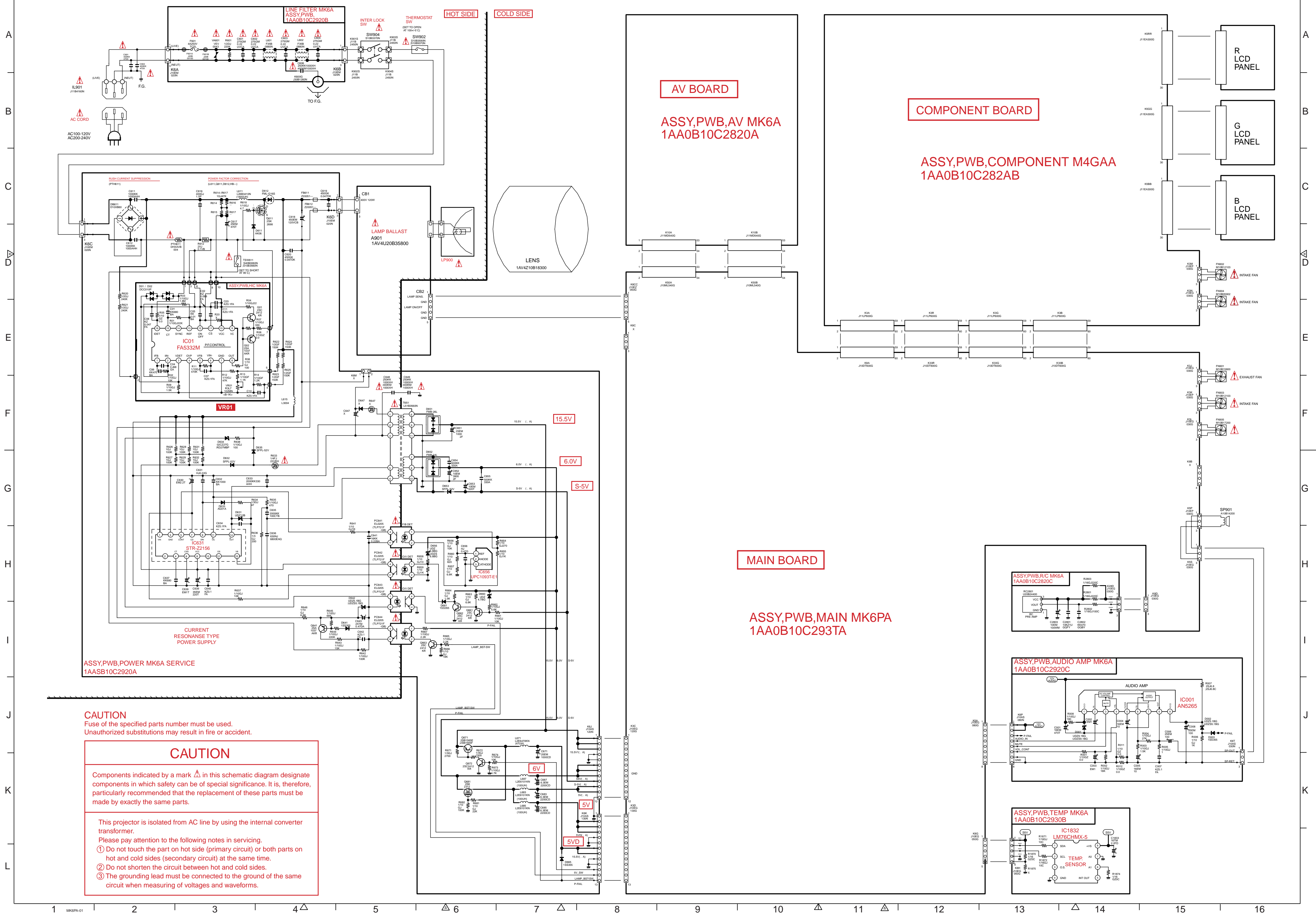

**CAUTION**  
Fuse of the specified parts number must be used.  
Unauthorized substitutions may result in fire or accident.

**CAUTION**  
Components indicated by a mark  $\Delta$  in this schematic diagram designate components in which safety can be of special significance. It is, therefore, particularly recommended that the replacement of these parts must be made by exactly the same parts.

This projector is isolated from AC line by using the internal converter transformer.  
Please pay attention to the following notes in servicing.  
① Do not touch the part on hot side (primary circuit) or both parts on hot and cold sides (secondary circuit) at the same time.  
② Do not shorten the circuit between hot and cold sides.  
③ The grounding lead must be connected to the ground of the same circuit when measuring of voltages and waveforms.



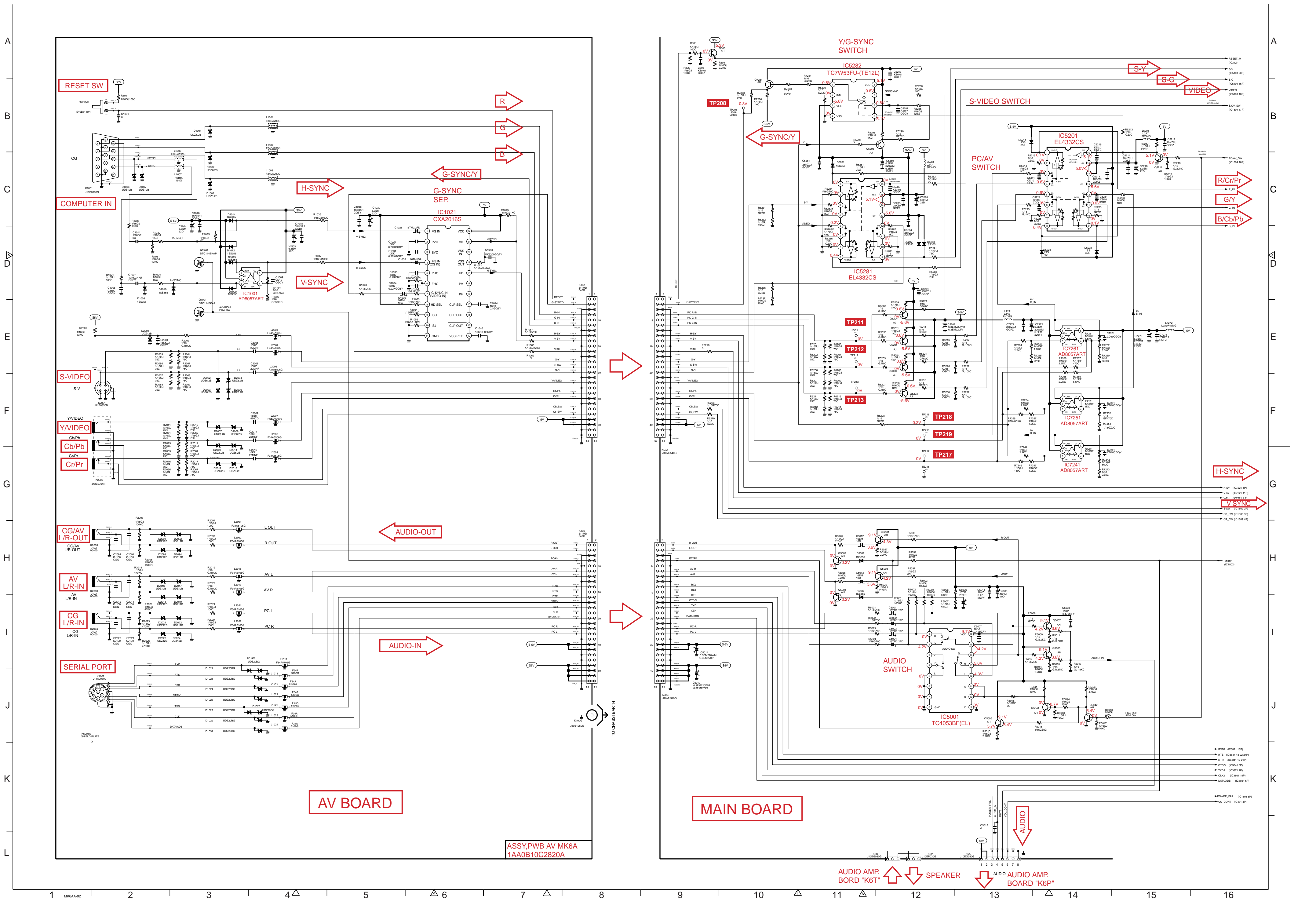

AV BOARD

MAIN BOARD

ASSY.PWB AV MK6A  
1AA0B10C2820A

AUDIO AMP. BORD "K6T" SPEAKER AUDIO AMP. BOARD "K6P"

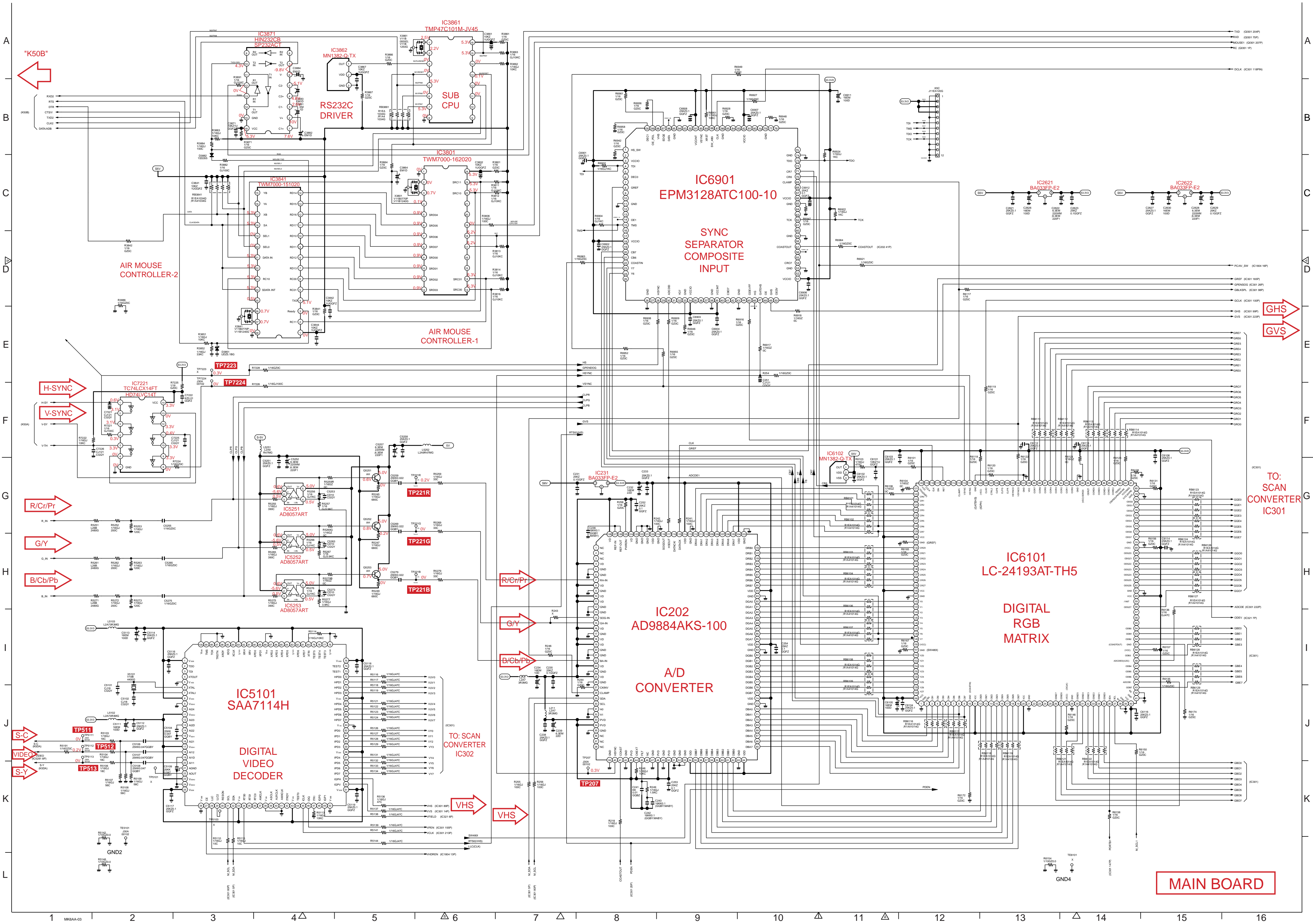



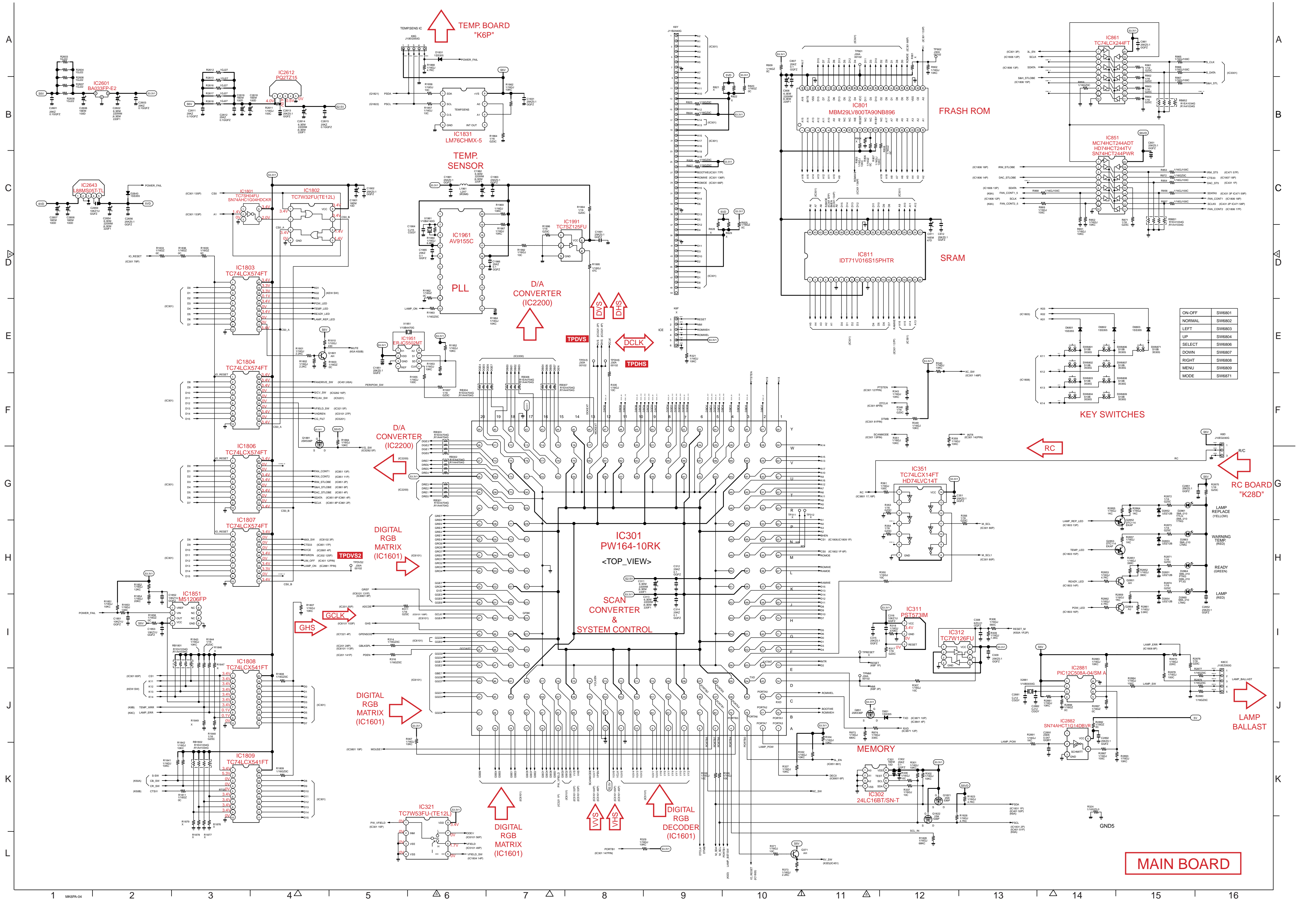



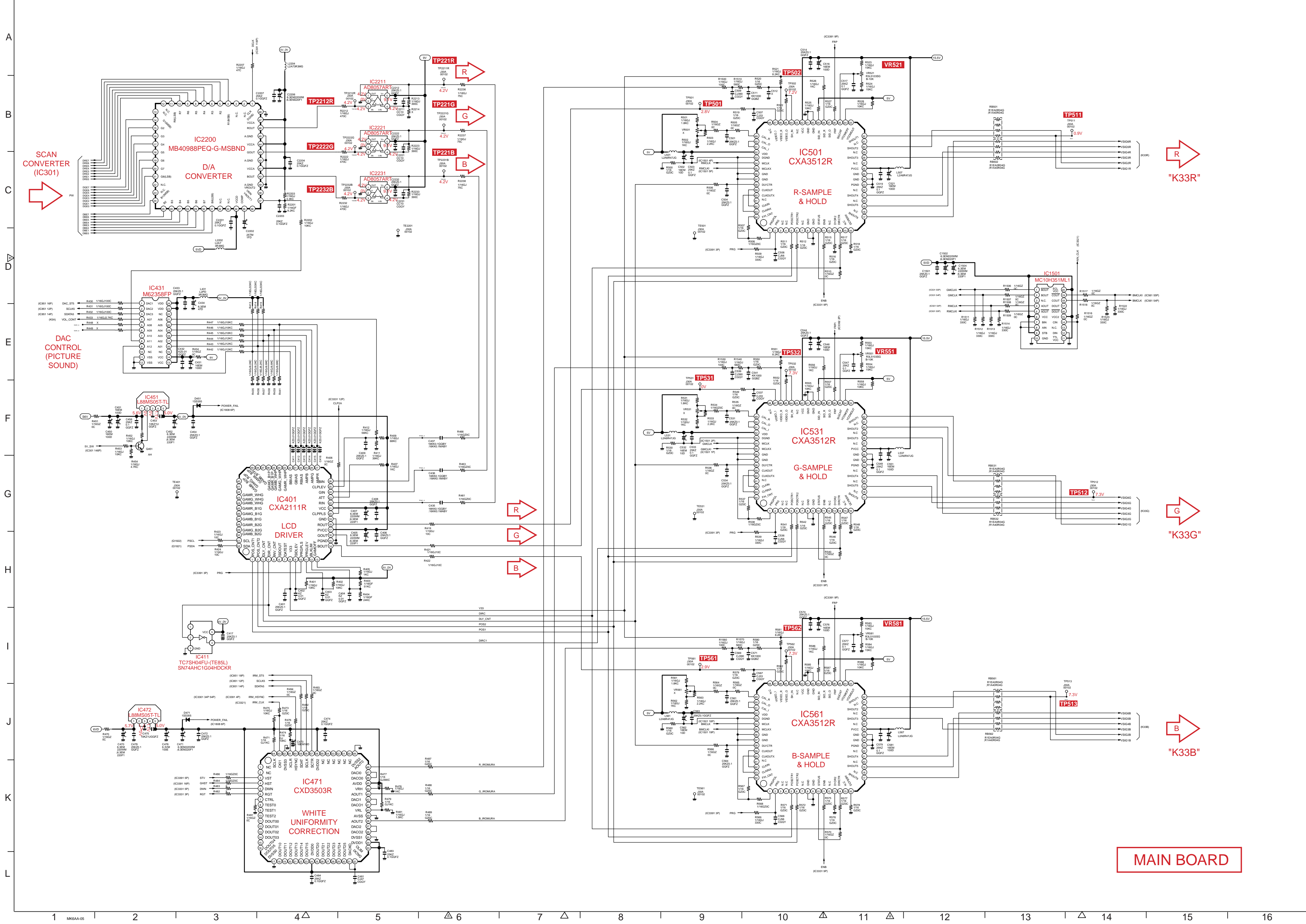

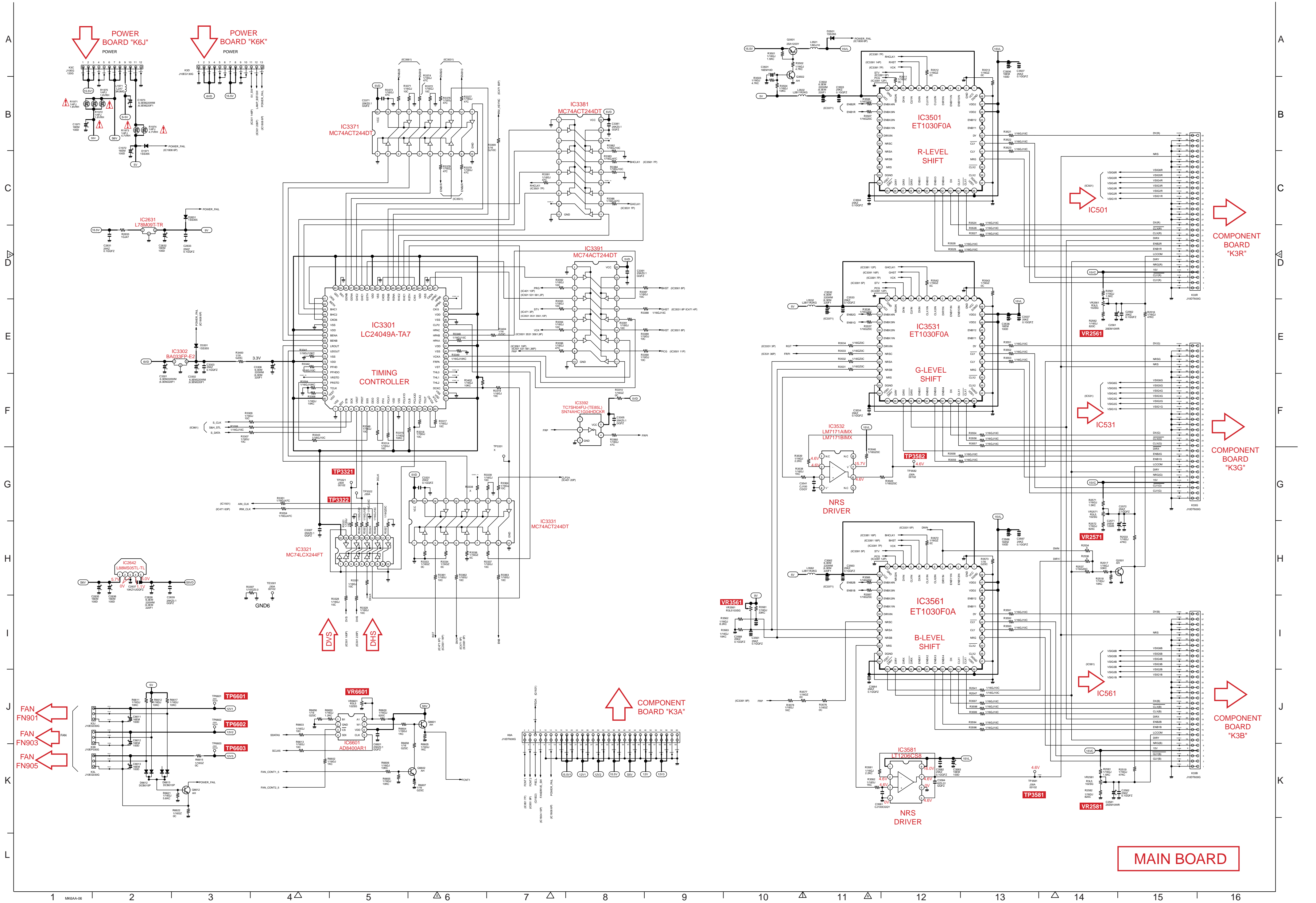



A  
B  
C  
D  
E  
F  
G  
H  
I  
J  
K  
L

A  
B  
C  
D  
E  
F  
G  
H  
I  
J  
K  
L

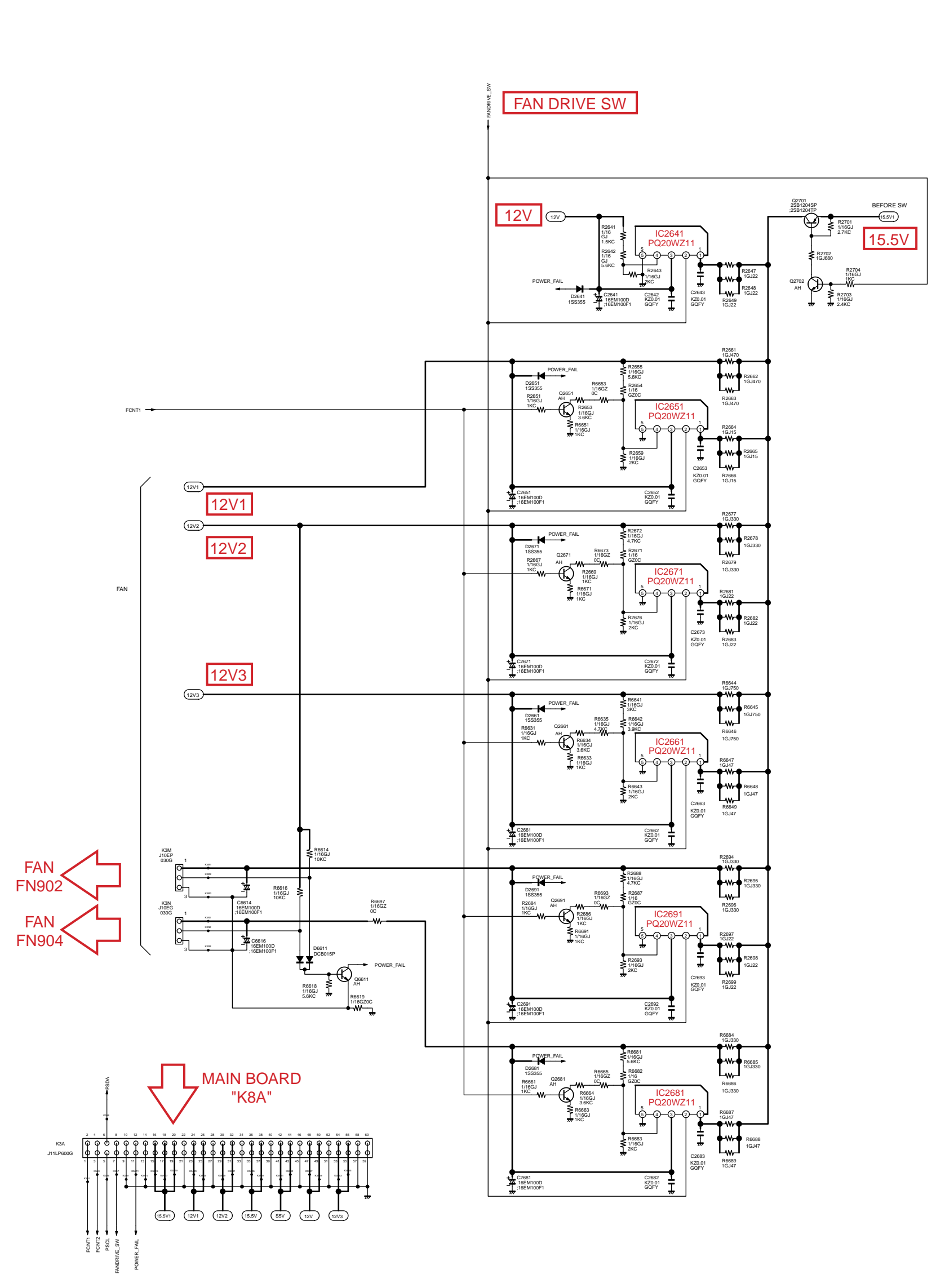

FAN FN902  
FAN FN904

MAIN BOARD "K8A"

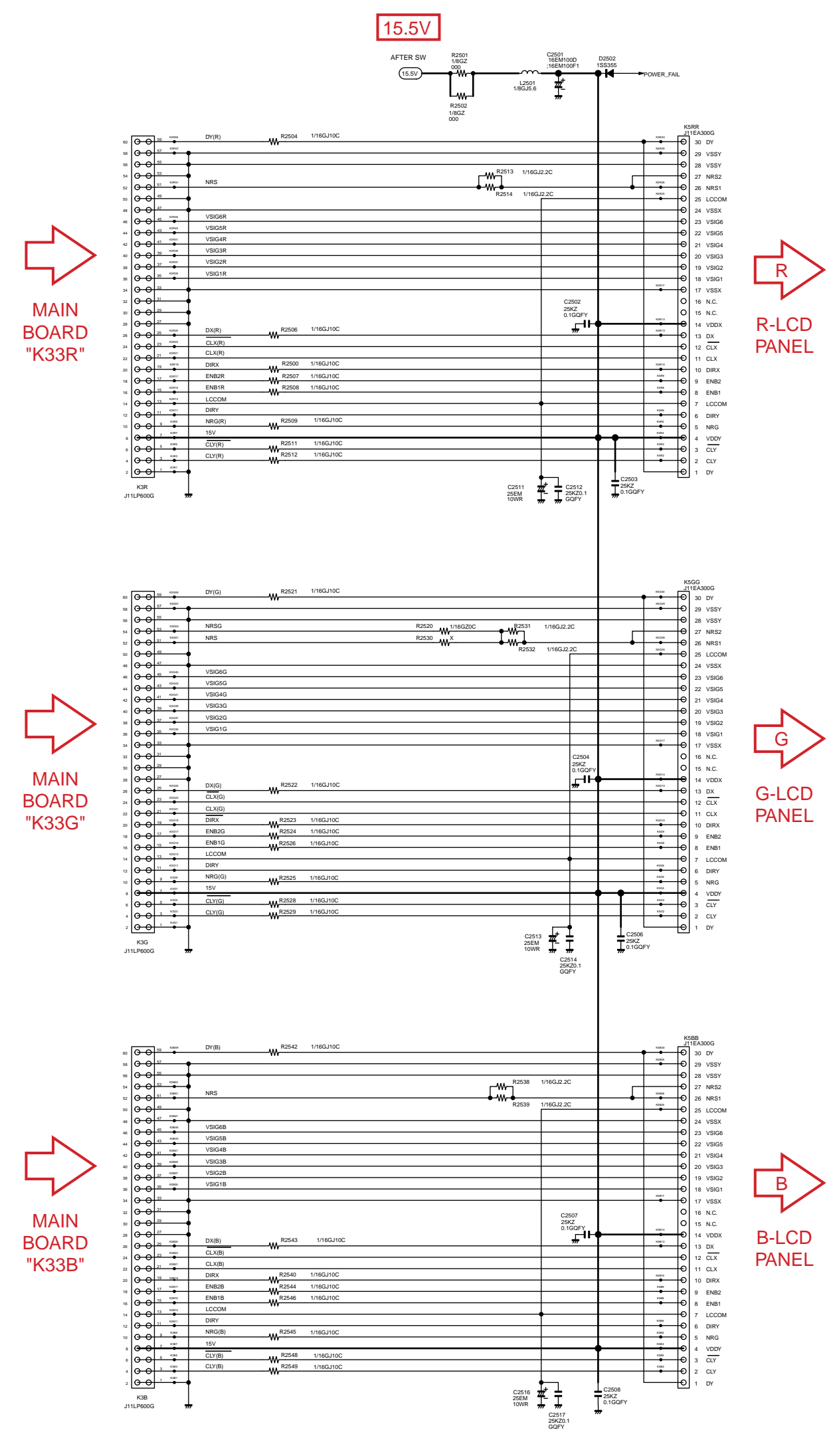

MAIN BOARD "K33R"

MAIN BOARD "K33G"

MAIN BOARD "K33B"

R  
R-LCD PANEL

G  
G-LCD PANEL

B  
B-LCD PANEL

COMPONENT BOARD

■ Printed Wiring Board Diagrams  
(LV-5110U/E)

⚠ CAUTION

This projector is isolated from AC line by using the internal converter transformer.  
Please pay attention to the following notes in servicing

1. Do not touch the part on hot side (primary circuit) or both parts on hot and cold sides (secondary circuit) at the same time.
2. Do not shorten the circuit between hot and cold sides.
3. The grounding lead must be connected to the ground of the same circuit when measuring of volt-ages and waveforms.

Power Board (SIDE:A)

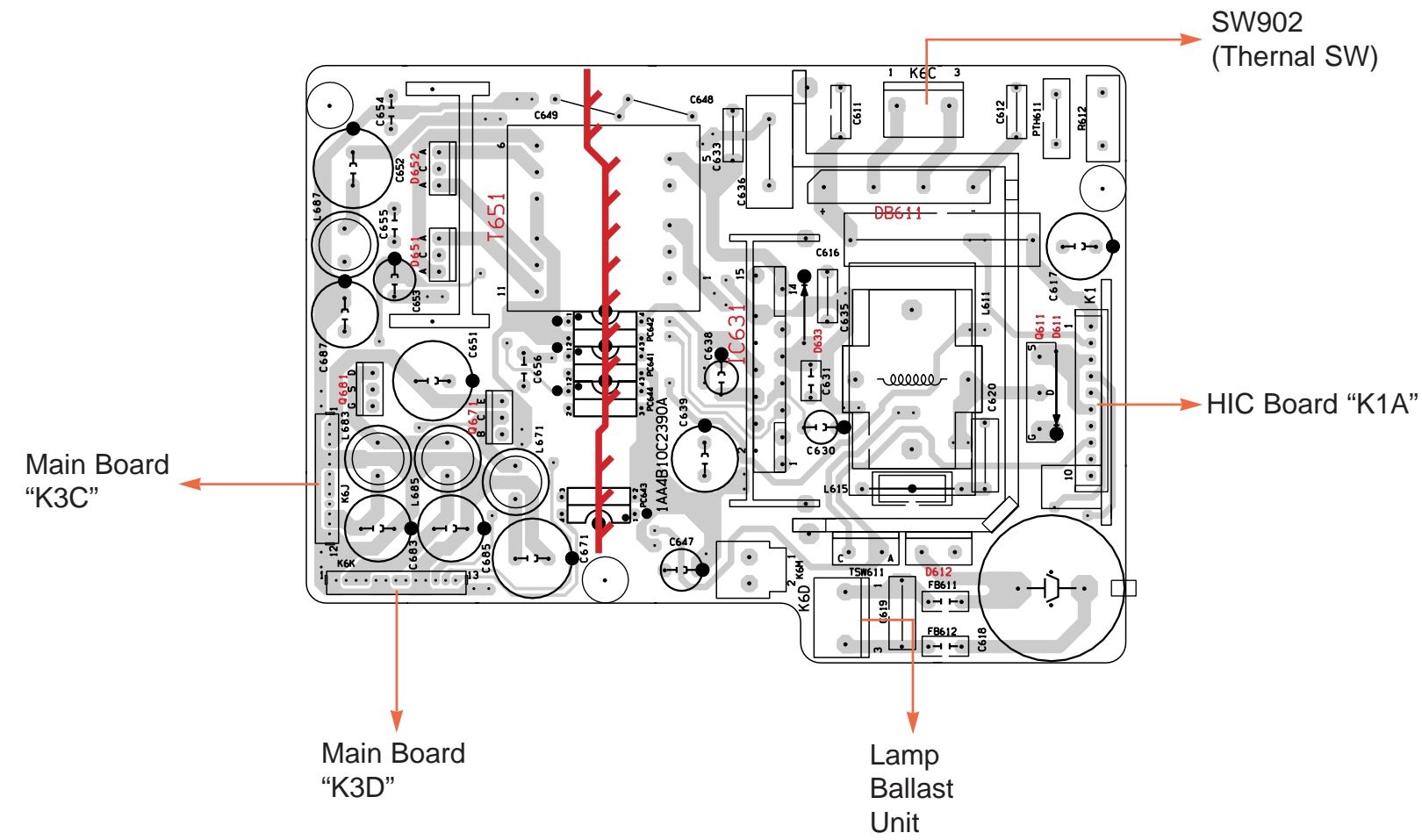

Power Board (SIDE:B)

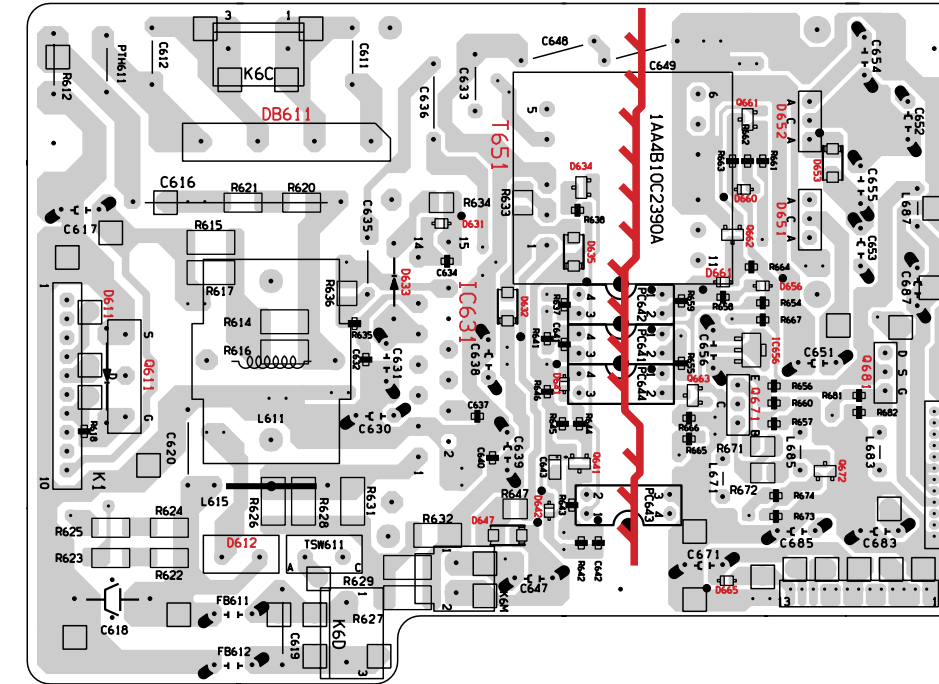

Line Filter Board (SIDE:A)

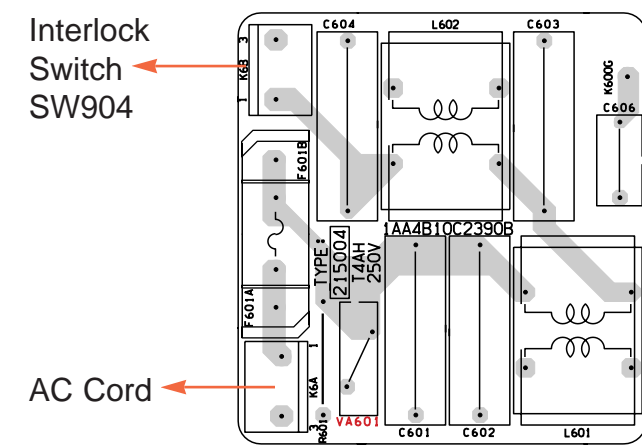

Audio Amp Board (SIDE:A)

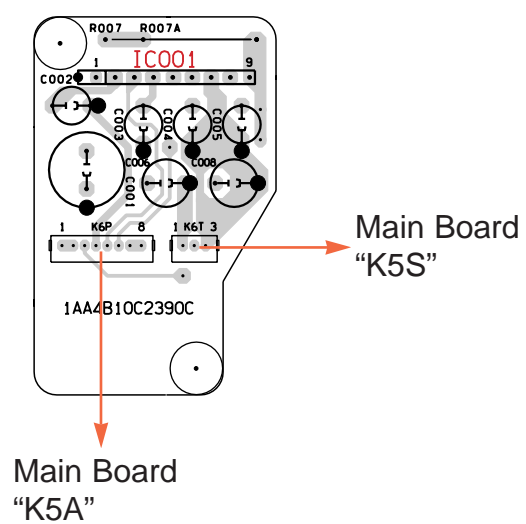

Line Filter Board (SIDE:B)

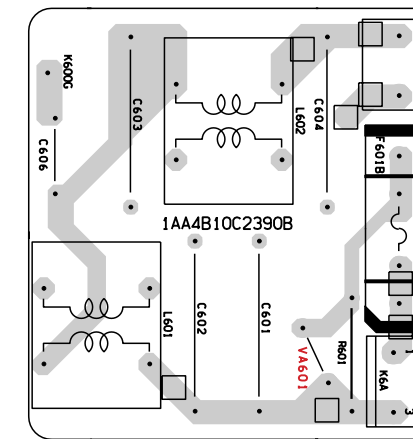

Audio Amp Board (SIDE:B)

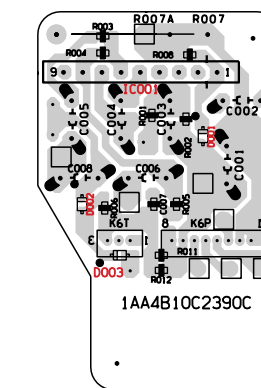

HIC Board (SIDE:A)

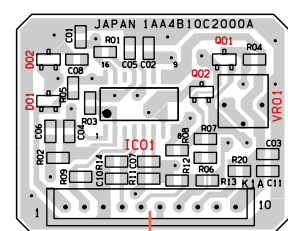

Temp Board (SIDE:A)

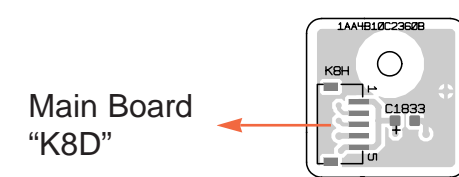

HIC Board (SIDE:B)

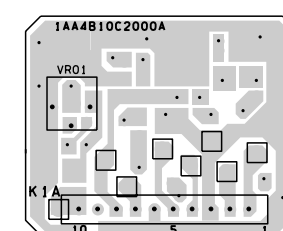

Temp Board (SIDE:B)

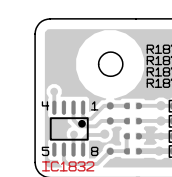

AV Board (SIDE:A)

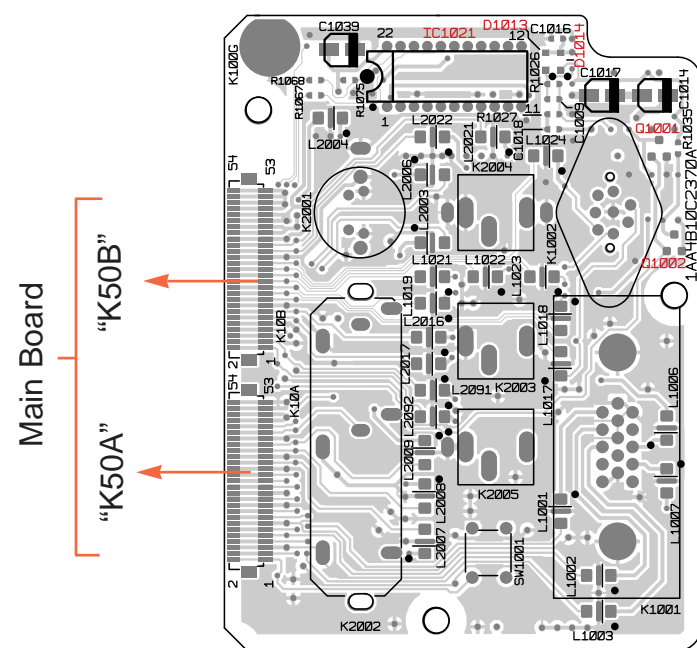

R/C Board (SIDE:A)

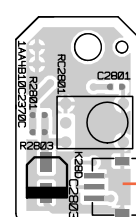

Main Board "K8D"

AV Board (SIDE:B)

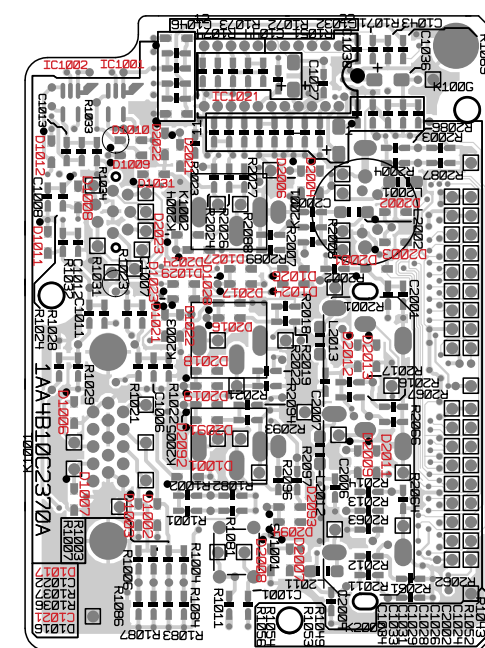

R/C Board (SIDE:B)

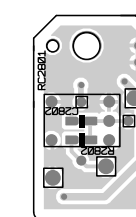

Component Board (SIDE:A)

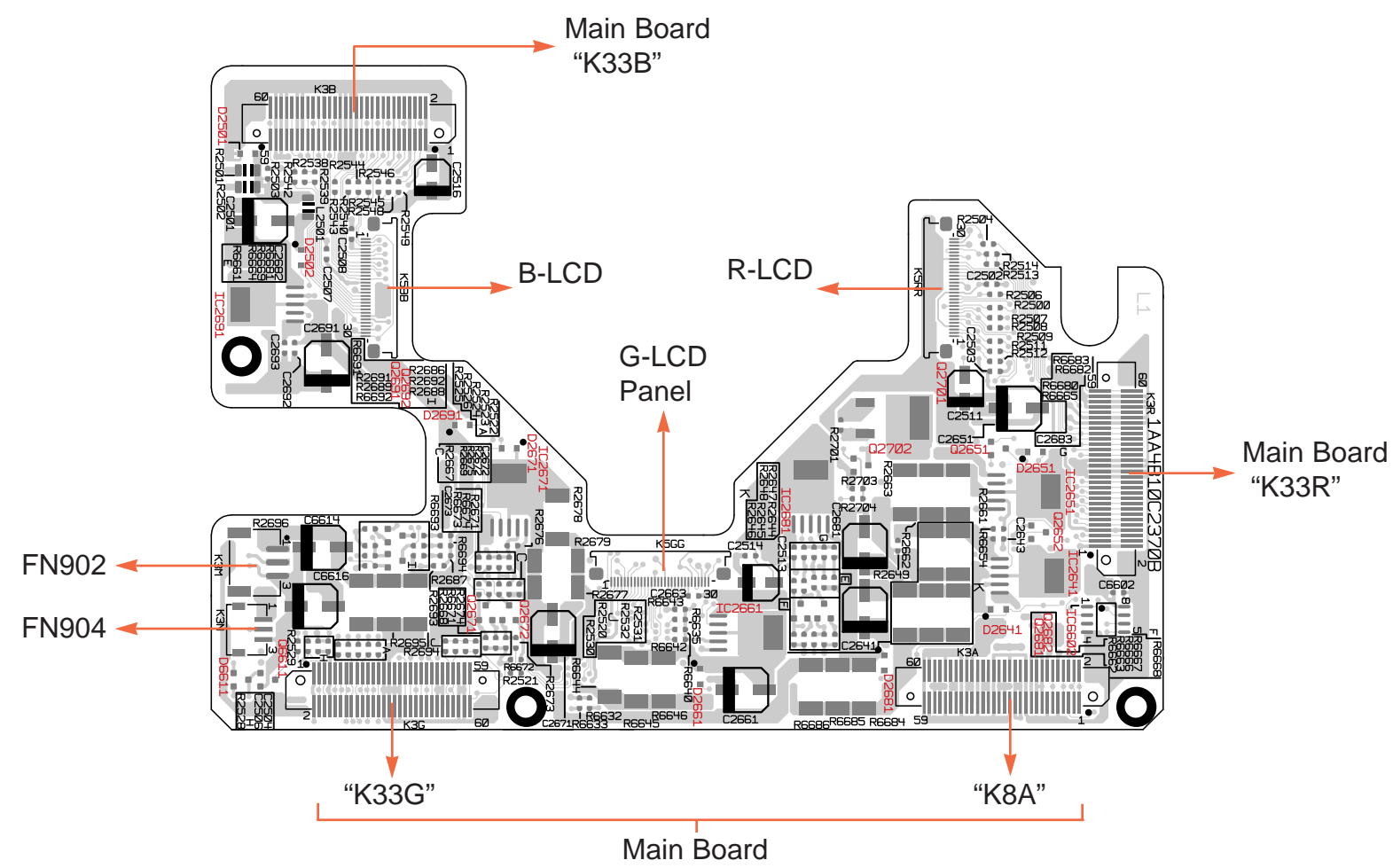

Component Board (SIDE:B)

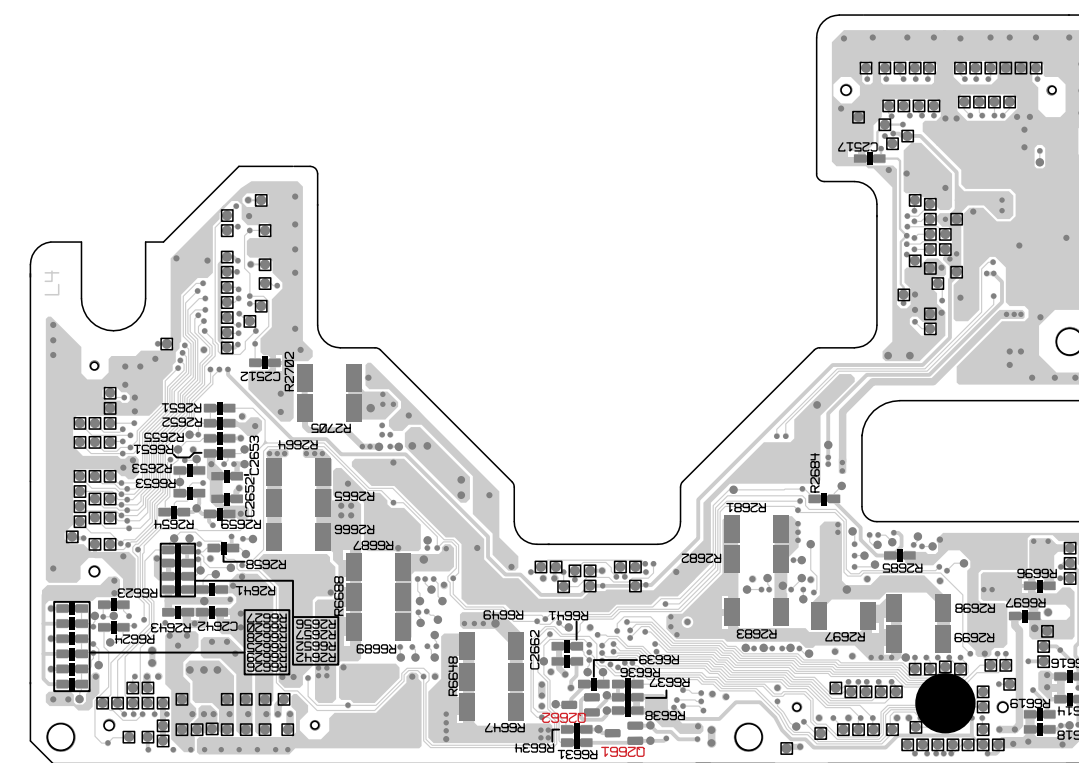



Main Board (SIDE:A)

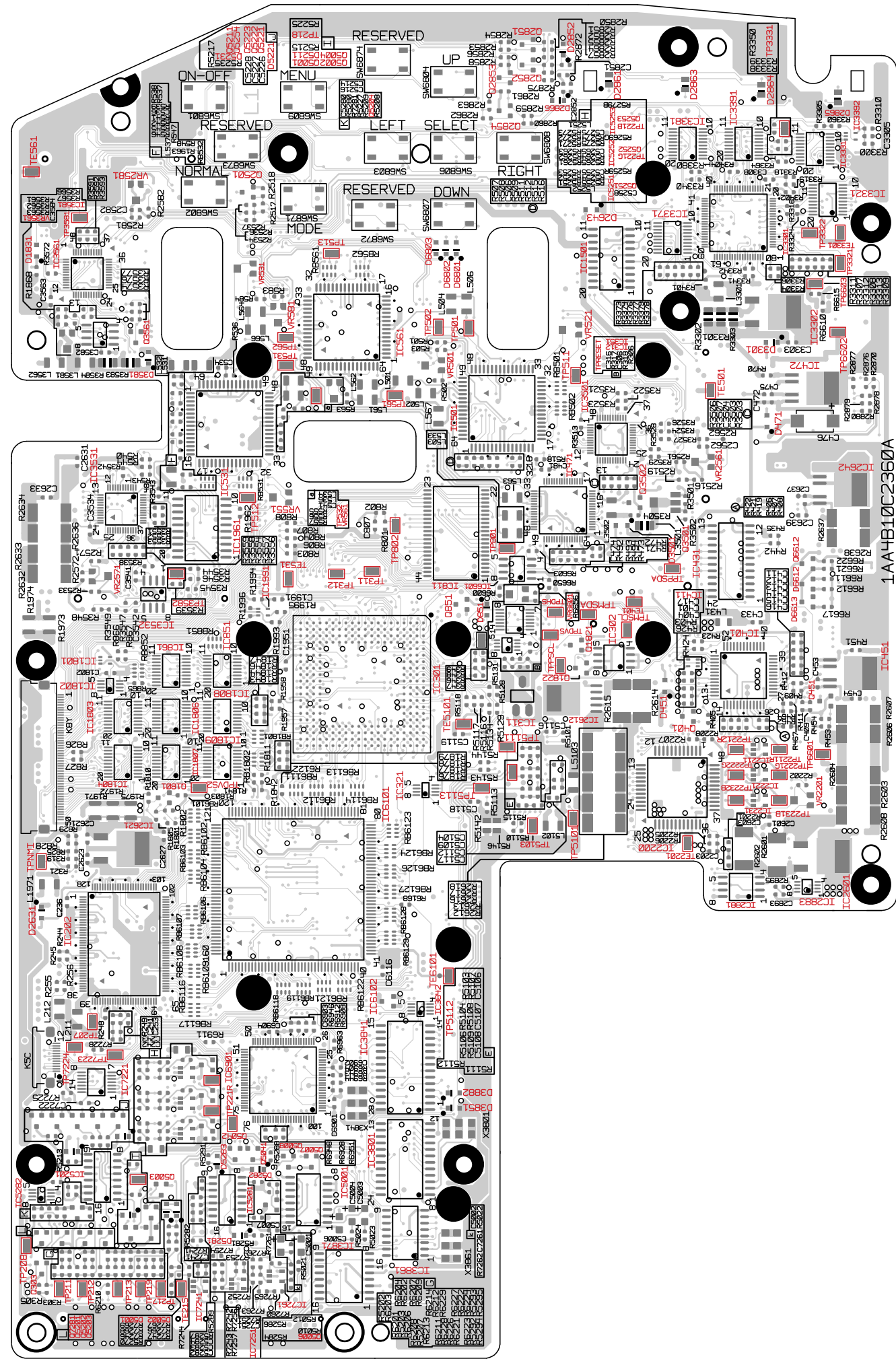

Main Board (SIDE:B)

